



Installation Operation Maintenance

LIFT™ 162-P-1204-P

Water-cooled heat pumps with scroll compressors
For hot water production at very high temperatures
Heating capacity 77-550 KW



	GENERAL	4		MAINTENANCE	29
1.1	PRELIMINARY PRECAUTIONS	4	8.1	MAINTENANCE	29
1.2	DOCUMENT INFORMATION	4	8.2	WEEKLY CHECKS	29
1.3	RANGE	5	8.3	MONTHLY CHECKS	29
1.4	ACCESSORIES	5	8.4	ANNUAL CHECKS	29
1.5	COMPLIANCE	5	8.5	WATER CIRCUIT	29
1.6	MACHINE IDENTIFICATION	5	8.6	REFRIGERANT CIRCUIT	30
1.7	INTENDED USE	5	8.7	DECOMMISSIONING AND DISPOSING	30
1.8	GENERAL PRECAUTIONS	5			
1.9	BASIC SAFETY RULES	6			
1.10	RESIDUAL RISK	6			
1.11	USER GUIDELINES	7			
1.12	MACHINE DESCRIPTION	7			
	SHIPMENT	8			
2.1	INSPECTION ON RECEIPT	8			
2.2	POSITION OF THE EQUIPMENT	8			
2.3	EQUIPMENT	8			
2.4	STORAGE	8			
2.5	HANDLING	8			
2.6	UNPACKING	9			
2.7	ACCESS TO INTERNAL PARTS	9			
2.8	RESTING ON THE GROUND	10			
	INSTALLATION	11			
3.1	INSTALLATION LOCATION REQUIREMENTS	11			
3.2	OPERATING LIMITS	11			
3.3	UNIT LOCATION	11			
3.4	VERIFYING CLEARANCES (CLEARANCE AREA)	12			
	WATER CONNECTIONS	13			
4.1	CONNECTION DIAGRAM	13			
4.2	POSITION OF CONNECTIONS	13			
4.3	HYDRAULIC DATA	13			
4.4	CONNECTION TO THE SYSTEM	14			
4.5	PV3E EVAPORATION CONTROL	14			
4.6	PV3C COLD START	15			
	ELECTRICAL CONNECTIONS	16			
5.1	MACHINE CONNECTION	16			
5.2	CONNECTIONS OF THE ACCESSORIES	16			
	COMMISSIONING	17			
6.1	PRELIMINARY INSPECTIONS	17			
6.2	FIRST START-UP OR RESTART AFTER LONG INACTIVITY	17			
6.3	SHUT-DOWN	17			
6.4	FLOW RATE CALIBRATION	18			
	CONTROL PANEL	19			
7.1	USER INTERFACE	19			
7.2	SWITCH ON AND OFF	21			
7.3	SETTINGS	21			
7.4	UNIT STATUS	23			
7.5	ALARMS	25			
7.6	LOGIN	27			
7.7	SOFTWARE	27			
7.8	ELECTRIC CONTROL INFORMATION	27			

1. General

- 1.1 Preliminary precautions
- 1.2 Document information
- 1.3 Range
- 1.4 Accessories
- 1.5 Compliance
- 1.6 Machine identification
- 1.7 Intended use
- 1.8 General precautions
- 1.9 Basic safety rules
- 1.10 Residual risk
- 1.11 User guidelines
- 1.12 Machine description

1.1 Preliminary precautions

- !** These units must be installed by a qualified company that at the end of the work provides the operator with a declaration of conformity with the regulations in force and the instructions provided by in this document.
- !** These units must comply with their intended use in line with their performance characteristics.
- !** Wear suitable and accident prevention clothing and equipment during installation and/or maintenance. The manufacturer declines any liability for non-compliance with safety and accident prevention regulations in force.
- !** All unit installation, connection, start-up and shut-down operations must only be implemented by qualified and authorised personnel.
- !** Comply with the laws in force in the country where the machine is installed, concerning the use and disposal of the packaging, the products used for cleaning and maintenance and for the management when the unit life cycle is complete.
- !** Any repairs or maintenance must be performed by the technical support of the manufacturer or by qualified personnel, in accordance with this document.
- !** Preferably use original spare parts when replacing components.
- !** If the outdoor or installation environment temperature can drop below zero, there is a freezing hazard and the heating water system must be drained or anti-freeze added.

1.2 Document information

- A Chapter
- B Sequence of paragraphs
- C Preliminary precautions
- D Operations

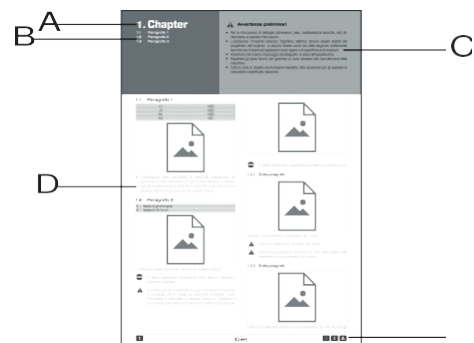

The manual is divided into chapters as follows:

- General;
 - Shipment;
 - Installation;
 - Water connections;
 - Electrical connections;
 - Commissioning;
 - Control;
 - Maintenance.
- The preliminary precautions must be read before performing any of the following operations.

This document uses the following definitions:

- Danger zones: any area inside and/or near the machine in which the presence of an exposed person constitutes a risk to his/her own health and safety.
- Exposed person: any person who is entirely or partially in a danger zone.
- Operator/Maintenance Technician: the person/s assigned to operate, adjust, service, repair or move the machine.

1.2.1 Symbols

- This publication contains the following symbols:

	Danger	Draws attention to actions that can cause serious injury if not performed correctly.
	Prohibited	Draws attention to actions that impose a prohibition.

1.3 Range

LIFT	
------	--

1.3.1 Available versions

LIFT	Heat Pump
------	-----------

1.4 Accessories

Factory fitted accessories

IM	Automatic circuit breakers
SL	Low noise version
RFM	Cooling circuit shut-off valve on discharge line
RFL	Cooling circuit shut-off valve on liquid line
PV3E	3-Way electronic pressostatic valve for evaporation control
PV3C	3-Way electronic pressostatic valve for cold start
SS	Soft start
IS	Modbus RTU protocol, RS485 serial interface
IST	Modbus TCP/IP protocol, Ethernet port
ISB	BACnet MSTP protocol, RS485 serial interface
ISBT	BACnet TCP/IP protocol, Ethernet port
ISL	LonWorks protocol, FTT-10 serial interface
ISS	SNMP protocol, Ethernet port
IAV	Remote set-point, 0-10 V signal
IAA	Remote set-point, 4-20 mA signal
IAS	Remote signal for second set-point activation
IDL	Demand limit from digital input
IVE	0-10 V signal for the management of the 3-Way electronic pressostatic valve for
IVC	0-10 V signal for the management of the 3-Way electronic pressostatic valve for cold start

Loose accessories

MN	High and low pressure gauges
CR	Remote control panel
AG	Rubber shock absorbers
AM	Spring shock absorbers

1.5 Compliance

The device complies with the following regulations:

- Machinery Directive 2006/42/CE
- PED Directive 2014/68/EU
- Electromagnetic Compatibility Directive 2014/30/UE
- LVD Directive: 2014/35/UE
- Energy Using Product directive 2009/125/EU and implementing regulations

1.6 Machine identification

A	Packaging plate
---	-----------------

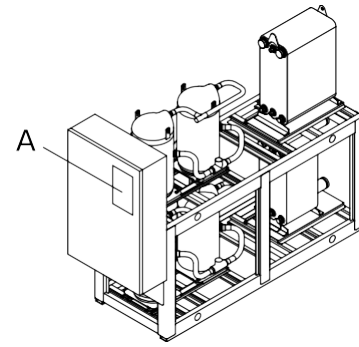
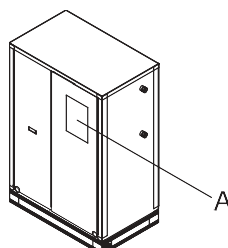

B	Frame feature plate
C	Electrical board feature plate

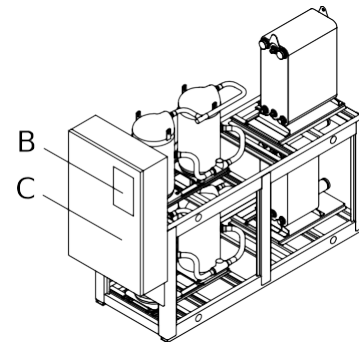
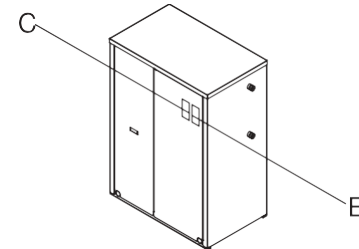

The equipment can be identified from:

- Packaging plate.
 - It shows the identification data of the equipment.
- Frame feature plate.
 - Affixed on the machine, it shows the technical and performance data of the equipment.
- Electrical board feature plate.
 - Affixed on the panel from which the electrical board is accessed, it shows the electrical data of the equipment.

If it is lost or deteriorated, request a duplicate from Technical Support.

- Tampering with, removal and deterioration of the identification plates complicate any installation, maintenance and spare part request.

1.7 Intended use

This unit is designed to heat water (possibly added with inhibited ethylene glycol) which circulates in a closed circuit.

The hot water produced can be used for air conditioning systems or for industrial processes.

- The machine cannot be installed outdoors.
- Any other use of the machine is forbidden.
- Do not use flammable products near the machine.
- Do not use substances that can form explosive mixtures close to the machine.
- Do not use the machine where there are problems of environmental impact.

1.8 General precautions

- If the refrigerant should leak, ventilate the room. The liquid refrigerant produces toxic gas when exposed to a flame.
- In the case of a malfunction or spill of liquid or gas refrigerant, set the main switch to "off" and close the shut-off valves. Promptly call technical support or professional personnel. Do not intervene personally on the unit.
- Based on CE Standard no. 842/2006 on certain fluorinated greenhouse gases, it is mandatory to indicate the total amount of refrigerant in the installed system. This information is present in the technical plate found in the outdoor unit.
- This unit contains fluorinated greenhouse gas covered by the Kyoto Protocol. Maintenance and disposal must be carried out only by qualified personnel.

1.9 Basic safety rules

Using products that require electricity and water require some basic safety rules to be complied with, such as:

- ⊘ It is prohibited to operate the unit before having disconnecting it from the power supply by setting the main switch to "off".
- ⊘ It is prohibited to modify the safety devices or the settings without authorisation and instructions from the manufacturer of the unit.
- ⊘ It is prohibited to pull, detach or twist the electrical cables coming from the unit, even if it is disconnected from the power supply.
- ⊘ It is strictly prohibited to touch any moving parts, stand between them or introduce pointed objects through the grids.
- ⊘ It is prohibited to use gas and water pipes to earth the unit.
- ⊘ It is prohibited to touch the unit when barefoot or with wet or damp parts of the body.
- ⊘ It is prohibited to stand on the unit, sit down on it and/or lean any type of object against it.
- ⊘ It is prohibited to dispose of and leave the packaging material in the reach of children as it can be a potential source of danger.
- ⊘ It is forbidden to release R134a into the atmosphere: R134a is a fluorinated greenhouse gas, recalled in the Protocol of Kyoto, with a Global Warming Potential (GWP)= 1430.

1.10 Residual risk

Description

The description of the residual risk considers the following elements:

- the type of dangers those working around the machine are subject to;
- a description of main risks;
- who could be exposed to such risks;
- what are the main safety measures adopted to reduce the risk of injury.

The guidelines for the prevention of accidents reported below, with reference to the relative areas of residual risk, must be integrated with all the general instructions of this chapter and with the accident prevention regulations in force in the destination country of the system.

Residual risk near the machine

- Electrocutation, if the electrical connection and earthing of the machine are not carried out correctly.
- Cuts or abrasions due to the presence of sharp edges.
- Suction of substances in the installation site and subsequent dispersion in the environment.
- Projection of any object that may fall on the fan blades.
- Leakage of water (in case of a fault).
- Formation of condensation water and ice in the area in front of the machine during the heating operation of the heat pump machines.
- Micro-climate alteration (during operation).
- Noise emission (during operation).
- Oil leaks (due to a fault).
- Refrigerant gas leak (due to a fault).

 Refrigerant gas is a greenhouse gas effect substance. Vapours are heavier than air and they can cause suffocation by reducing oxygen available for breathing. Rapid evaporation of the liquid can cause freezing.

Measures to be adopted if refrigerant gas leaks:

- R134a

First aid measures

- General information:
 - do not administer anything to an unconscious person.
- Inhalation:
 - transfer outdoors.
 - use oxygen or artificial respiration if needed.
 - do not administer adrenaline or similar drugs.
- Contact with eyes:
 - rinse thoroughly with plenty of water for at least 15 minutes and consult a doctor.
- Contact with skin:
 - wash immediately with plenty of water
 - immediately remove all contaminated clothing

Measures in the event of accidental spillage

- Personal precautions:
 - Move all personnel to safe areas.
 - Provide adequate ventilation.
 - Use personal protective equipment.
- Environmental precautions:
 - Intercept the emission.
- Cleaning methods:
 - Use absorbent products.

Operations with removed panels

Some of the operations and/or tests described below require the removal of the panels to access inside the unit.

There may be hot surfaces (piping, compressor, etc.) or cold (compressor, intake separator, etc.), sharp edges (coil fins) or moving parts (fans) even with the machine stationary.

 The power supply must be disconnected before removing any panel.

 Operations that require the panels to be opened must only be carried out by qualified personnel wearing personal protective equipment.

1.11 User guidelines

- Keep this manual together with the wiring diagram in a place that is accessible by the operator.
- Take note of the unit identification data so as to provide them to the service centre when required (see the "Machine identification" paragraph).
- It is recommended to keep track of the operations carried out on the unit, so as to facilitate any troubleshooting.
- In case of a fault or malfunction:
 - verify the type of alarm to notify the service centre;
 - immediately disable the unit without resetting the alarm;
 - contact an authorised service centre;
 - request original spare parts.
- Request the installer to be trained on:
 - switching on/shut-down;
 - shutting down for long periods;
 - maintenance;
 - what to do/not to do in case of a fault.

1.12 Machine description

1.12.1 Features

Frame.

Self-supporting galvanized steel frame further protected with polyester powder painting. Easy to remove panels allow access to the inside of the unit for maintenance and other necessary operations.

Compressors.

Scroll with oil sight glass. They are fitted with internal overheat protection and crankcase heater. They are installed on rubber shock absorbers.

Condenser.

AISI 316 stainless steel braze welded plate type, with one circuit on the refrigerant side and one on the water side in 162-P - 602-P models; with two independent circuits on the refrigerant side and one on the water side in 804-P- 1204-P models, complete with water differential pressure switch.

Evaporator.

AISI 316 stainless steel braze welded plate type, with one circuit on the refrigerant side and one on the water side in 162-P- 602-P models; with two independent circuits on the refrigerant side and one on the water side in 804-P- 1204-P models, complete with water differential pressure switch.

Electrical board.

It includes main switch with door safety interlock; fuses; thermal relays for compressors protection; interface relays; electrical terminals for external connections.

Microprocessor

For automatic control of the unit, allowing continuous display of the operational status of the unit, control set and real water temperature and, in case of partial or total block of the unit, indication of security device that intervened.

Cooling circuit

Made of copper pipe, it includes the following components on all models: electronic thermostatic expansion valve; filter drier; liquid and humidity indicator; high and low pressure switches (with fixed setting); safety valve; check valves.

User side water circuit

It includes condenser; temperature sensors; water differential pressure switch.

Source side water circuit

It includes evaporator; temperature sensors; water differential pressure switch.

2. Shipment

- 2.1 Inspection on receipt
- 2.2 Position of the equipment
- 2.3 Equipment
- 2.4 Storage
- 2.5 Handling
- 2.6 Unpacking
- 2.7 Access to internal parts
- 2.8 Resting on the ground

2.1 Inspection on receipt

A Packaging plate

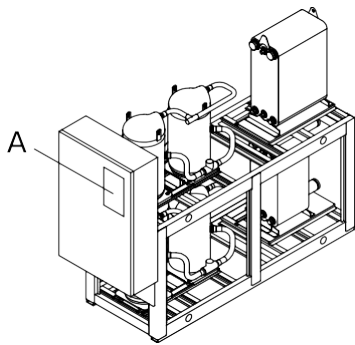
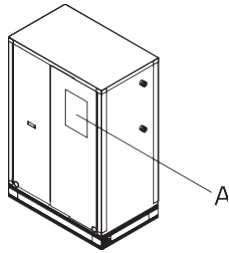

- Before accepting the delivery, check:
 - That the unit has not been damaged during transport.
 - That the delivered material is as specified on the shipping document when comparing the data with the package plate 'A'.
- In case of damage or faults:
 - Immediately take note of the damage on the shipping document and write: "Accepted with reservations for evident loss/damage during transport".
 - Contest with registered letter to the carrier and supplier.

2.2 Position of the equipment

A Pocket for documents

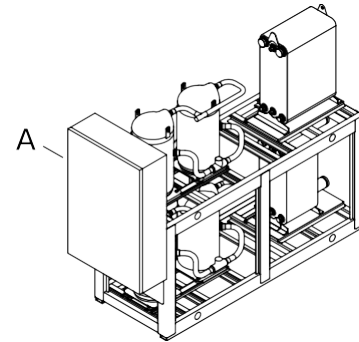
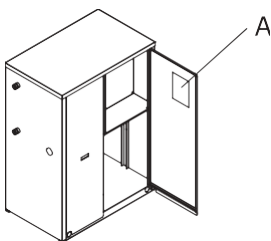

⚠ Keep the documentation in a dry place to prevent deterioration, for at least 10 years for future reference.

⚠ Any accessories that are not factory-fitted are supplied in separate packages, with a relevant instruction sheet.

2.3 Equipment

- Installation, operation and maintenance manual;
- Wiring diagram;
- Refrigerant diagram;
- Water diagram;
- List of parameters;
- Declaration of conformity;
- Technical data.

2.4 Storage

The room temperature in which the units are stored must be between $-20 / +50^{\circ}\text{C}$.

2.5 Handling

- The equipment is designed for two lifting systems according to the length of the machine.

⚠ Do not use the pipes or other components of the machine as lifting points.

2.5.1 Lifting with forks

A Support

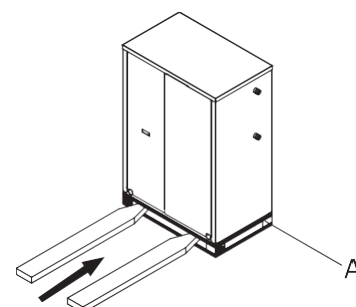

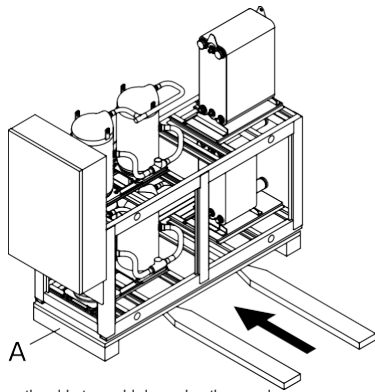

- Insert the forks from the side to avoid damaging the panels.
- Before placing the machine on the ground remove the wooden supports.

2.5.2 Lifting with a crane

A	Bar for lifting (maximum \varnothing 63 mm)
B	Hole to insert the lifting bar
C	Label for holes enabled for lifting

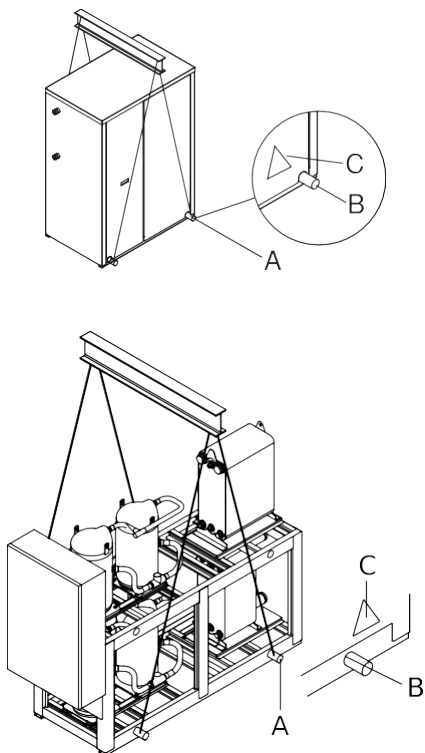

⚠ It is recommended to use a system to prevent the belts from slipping from the bars during lifting.

⚠ Place spacers and protectors in between prevent damaging the unit.

- Insert the lifting bars into the arranged holes on the base and indicated by the relative labels.
- Lift the unit using suitable belts.

⚠ Make sure that all the equipment used for handling (belts, bars, etc.) are appropriate for the weight of the unit.

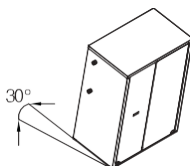

⚠ Do not exceed the maximum inclination allowed, as shown in the figure.

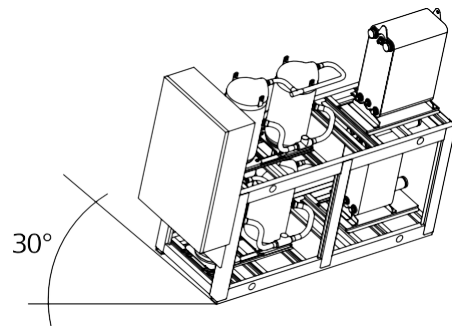

2.6 Unpacking

A	Wooden support
B	Corner protector

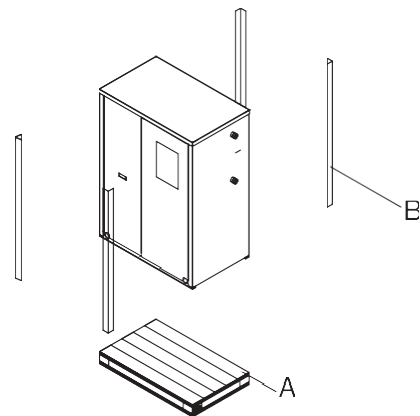

- Remove the wooden supports before resting it definitely on the ground.
- Remove the clear film that wraps the machine.
- Remove the corner protectors.

⚠ The machine is supplied without shock absorbers. Install any shock absorbers before setting the machine on the ground.

⚠ Only remove the packaging when set in the place of installation.

2.7 Access to internal parts

A	Electrical board door
B	Front panel

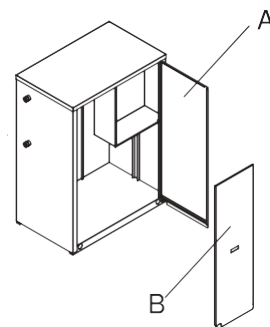

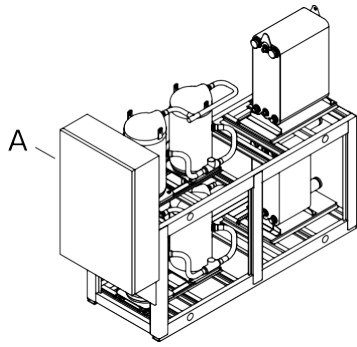

- Unscrew the fixing screws and remove the panels.

To access the electrical board:

- Remove the panels of the electrical board.
- Set the disconnecting switch knob to Off.
- Open the doors of the electrical board.

2.8 Resting on the ground

The unit must be positioned on a perfectly horizontal surface that is able to withstand its weight. Positioning must be performed slowly and so that all support points are touching the floor.

3. Installation

- 3.1 Installation location requirements
- 3.2 Operating limits
- 3.3 Unit location
- 3.4 Verifying clearances (clearance area)

3.1 Installation location requirements

The installation place must be chosen as specified in standard EN 378-1 and the requirements of standard EN 378-3. In any case, the installation site must consider the risks associated with an accidental leak of refrigerant gas contained in the direct expansion units. Do not install the unit near flammable materials or others that could cause a fire. Provide specific fire-fighting measures.

3.2 Operating limits

The operating limits are indicative, near the operating range limits the units may choke the cooling capacity.

Check the actual capacity by using the capacity tables or the selection software.

Operating mode: heating

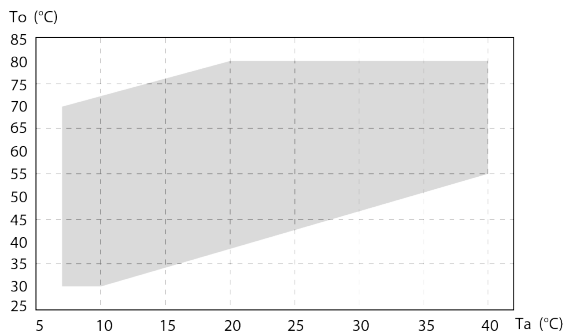

Tevap Evaporator outlet water temperature (°C)

Tcond Condenser outlet water temperature (°C)

Standard operation

3.3 Unit location

3.3.1 Noise

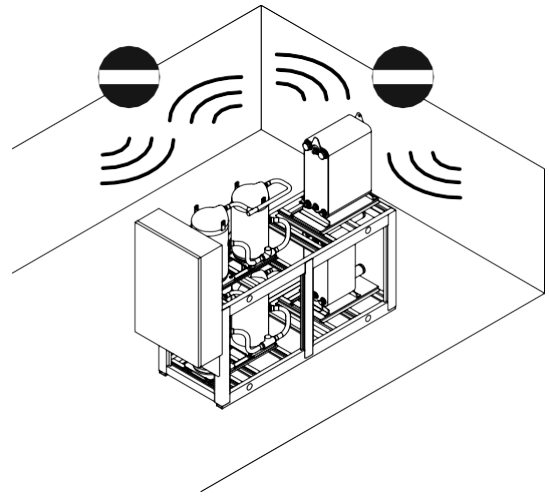
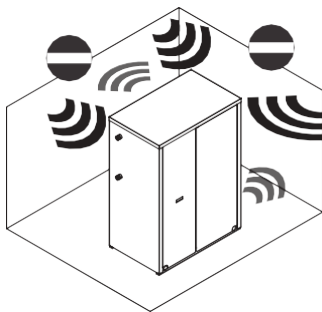

During operation, the unit generates noise.

⚠ Avoid installation in reverberant environments.

3.3.2 Resting on the ground

- A Rigid rubber band
- H Slab of 10-15 cm

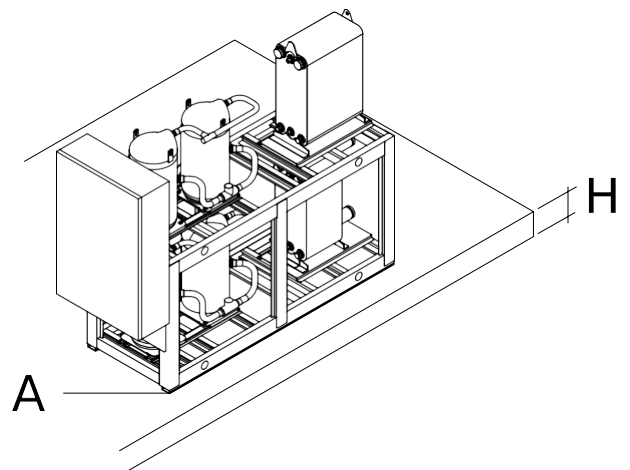
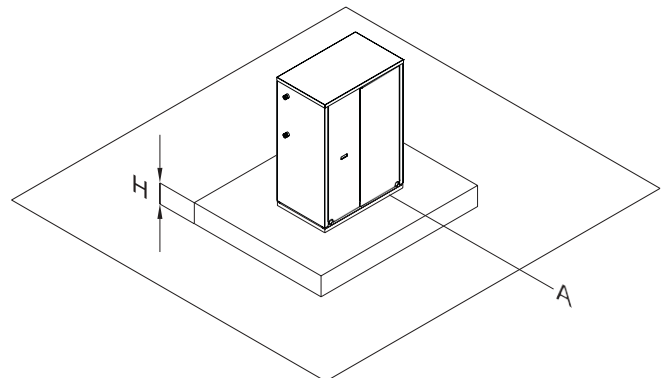

- Place the unit on a perfectly level support surface.

Place a rigid rubber band between the base of the machine and the support surface.

- ⚠ Verify that the support surface withstands the weight of the unit.
- ⚠ Provide a supporting slab of proportional dimensions with the unit if resting on unstable ground.
- ⚠ The slab must be horizontal and able to withstand approximately 200% of the operating weight of the machine.
- ⚠ If necessary, use shock absorbers (rubber or spring).

3.4 Verifying clearances (clearance area)

L1	0
L2	800
W1	300
W2	300

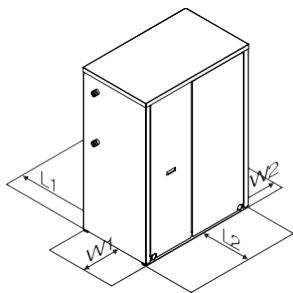

L1	500
L2	500
W1	800
W2	500

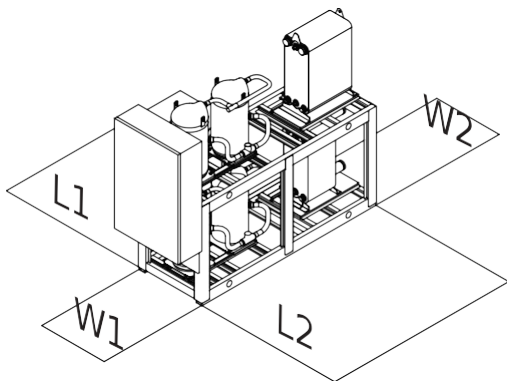

- Installation, in addition to the indicated spaces, must enable access to the authorised personnel for maintenance operations and must take into account the safety distances from any other equipment installed near the machine.

4. Water connections

- 4.1 Connection diagram
- 4.2 Position of connections
- 4.3 Hydraulic data
- 4.4 Connection to the system
- 4.5 PV3E evaporation control
- 4.6 PV3C cold start

4.1 Connection diagram

1	Unit
ANT	Anti-vibration joint (recommended)
CV	Check valve
FL	Flow switch (mandatory)
FTR	Mesh filter (mandatory)
MN	Water gauge
MP	Circulating pump
RI	Shut-off ball valve
RIC	Automatic water filling valve
SFA	Automatic air vent (mandatory)
ST	Inertial tank
VE	Expansion vessel
VSI	Safety valve (mandatory)

User side

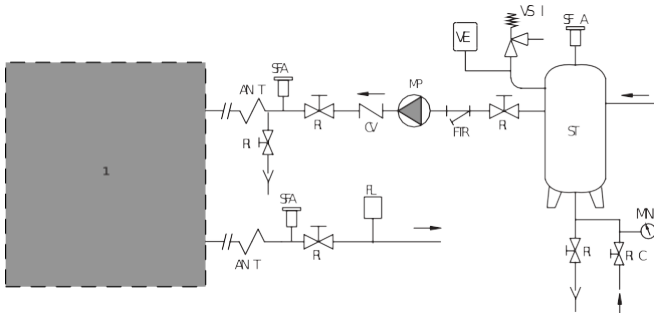

Source side

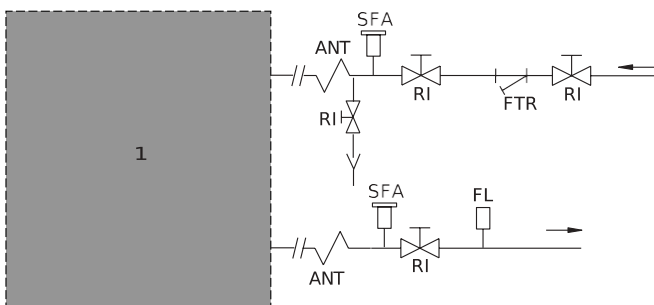

⚠ Some of the components in the diagram may already be included in the unit with the hydronic kit. Those not included must be provided by the installer.

⚠ Connection pipes must have a suitable diameter and be supported so as not to impose their weight on the unit.

4.2 Position of connections

The position of the water connections and the inlet and outlet direction is indicated by the labels on the connections.

4.3 Hydraulic data

4.3.1 Water volume

The machine electronic control, to protect the electrical motor, limits hourly start up of the compressor.

This operation creates oscillations of the water temperature in the draw-off point, affecting plant efficiency.

For a correct operation, the water volume must comply with the following formula:

$$M > 9,45 \times k \times n / N \times (Q_f - q)$$

M = Minimum water content (l);

k = Factor that takes into account the different water temperature value between the inlet and outlet of the evaporator or condenser;

n = Coefficient of capacity control (n = 1 unit up to 4 compressors; n = 2 units with more than 4 compressors);

N = N. compressors;

Q_f = Cooling capacity and heating capacity (kW);

q = Permanent thermal load in the system (kW), (q = 0 if the value is unknown).

ΔT (K)	K
3	1
4	1
5	1
6	1.05
7	1.1
8	1.15
9	1.2
10	1.25

⚠ For the process application a 50% higher water content is recommended to stabilize the outlet temperature (1.5 x M calculated with the previous formulas).

4.3.2 Water features

Water features are important for the proper operation of the machine and for its lifetime.

Extreme water hardness leads to the formation of limestone in exchangers reducing their performance.

The table shows some water parameters to be observed for proper operation of the machine.

Content	Concentration mg/l or ppm	Material	
		AISI 316L	Copper
pH	<6	2	2
	6-7.5	2	2
	7.5-9	1	1
	>9	1	2
	- <70	1	2
Alkalinity	HCO ₃	1	1
	>300	1	2
	<70	1	1
Sulphate	SO ₄ ²⁻	1	3
	>300	1	3
	>1	1	1
Alkalinity/Sulphate	HCO ₃ -/SO ₄ ²⁻	1	3
	<1	1	3

Content		Concentration mg/l or ppm	Material	
Electrical conductivity	µS/cm	<10	1	2
		10-500	1	1
		>500	1	2
Ammonium	NH4	<2	1	1
		2-20	1	2
		>20	1	3
Free chlorine	Cl2	<1	1	1
		1-5	3	1
		>5	3	3
Hydrogen Sulphide	H2S	<0.05	1	1
		>0.05	1	3
Free Carbon Dioxide	CO2	<5	1	1
		5-20	1	2
		>20	1	3
Nitrate	NO3	<100	1	1
		>100	1	2
Iron	Fe	<0.2	1	1
		>0.2	1	2
Aluminium	AL	<0.2	1	1
		>0.2	1	2
Manganese	MN	<0.1	1	1
		>0.1	1	2

- 1 - Good corrosion resistance.
2 - If different factors of this type are present, corrosion can occur.
3 - Use not recommended.

4.3.3 Protection against freezing

If you do not wish to drain the system during periods where the machine is not used, the water may freeze, or if the system must operate with temperatures less than 5°C, ethylene glycol must be mixed with the water.

Adding glycol changes the physical characteristics of the water and the performance of the machine.

The table indicates the multiplicative factors to calculate the performance change based on the percentage of glycol used.

% G	10	20	30	40	50
Tc	-4.5	-9.5	-15.5	-21.5	-32.5
CQ	0.975	0.953	0.931	0.914	0.882
CP	0.998	0.995	0.99	0.985	0.975
CG	1.01	1.04	1.08	1.14	1.2
CP	1.05	1.13	1.21	1.26	1.32

- % G = Glycol percentage
Tc = Water freezing temperature (°C)
CQ = Cooling capacity correction factor
CP = Electrical power absorbed correction factor
CG = Water flow correction factor
Cp = Pressure drops correction factor

4.4 Connection to the system

4.4.1 Models without hydronic kit

- A: Condenser connections (user side);
B: Evaporator connections (source side);

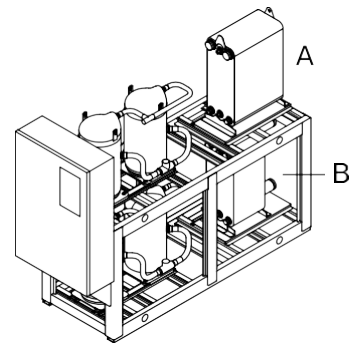
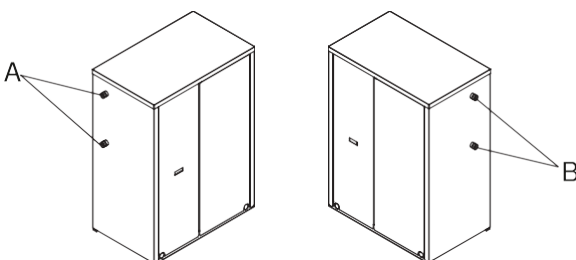

In these models, the connections are positioned outside the unit.

- Remove the protection caps from the connections.
- Connect the pipes to the connections.

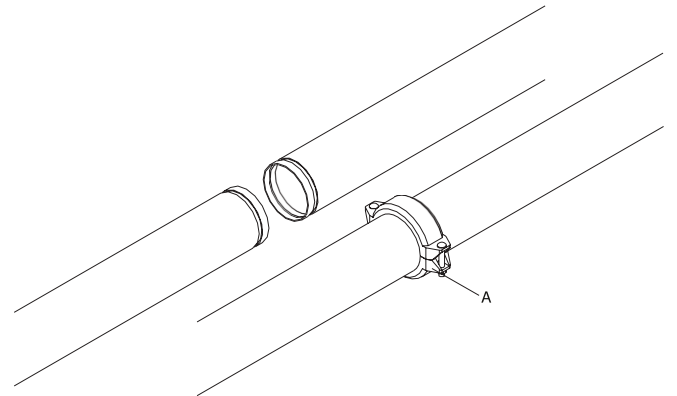

All exchangers that can be connected directly are equipped with grooved connections. The units are all supplied with tubes with grooved connection on one side and welding connections on the external side, together with the relevant connecting clamp and gasket. These allows the installer to make the most appropriate connection. By welding, in fact, it is possible to connect a threaded or flanged sleeve or even a grooved sleeve for a grooved connection.

⚠ Provide shut-off valves and anti-vibration joints on the connection pipes.

⚠ During the hydraulic connection operations, never operate with free flames near or inside the unit.

4.5 PV3E evaporation control

On the source side there is a limit on the inlet temperature of 45 ° C.

If there are applications in which it is necessary to enter with water at a higher temperature, it is necessary to adopt an evaporation control by means of a 3-Way valve following the diagram shown below.

The proposed scheme must be respected to allow the maintenance of the flow rate to the exchanger (Evaporator), it also allows the control of the inlet temperature of the evaporator by injecting cold water.

The analogue control signal comes directly from the unit control.

If the 3-way valve is not supplied, bear in mind that the control signal is only and exclusively 0-10V (IVE option).

The servomotor, therefore, must necessarily be able to be controlled by this signal.

⚠ The valve is supplied, but the installation must be carried out on site following the principle diagram shown.

⚠ The valve must be installed near the unit.

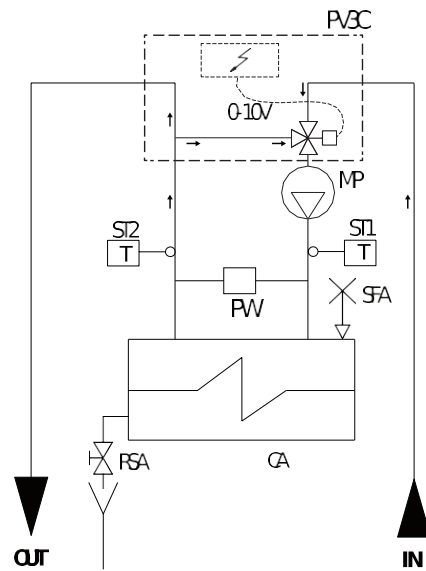
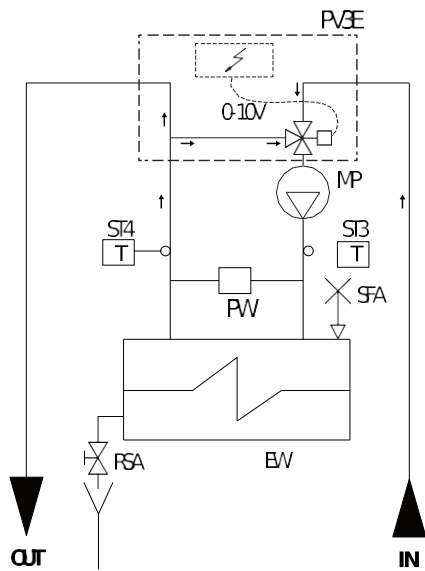

In	Input
Out	Output
ST3	Temperature probe
ST4	Temperature probe
SFA	Air vent valve
RSA	Water drain valve
PW	Differential pressure switch
CA	Condenser
MP	Circulating pump
PV3E	Evaporation control valve

In	Input
Out	Output
ST1	Temperature probe
ST2	Temperature probe
SFA	Air vent valve
RSA	Water drain valve
PW	Differential pressure switch
CA	Condenser
MP	Circulating pump
PV3C	Cold start valve

4.6 PV3C cold start

If in the applications a system cold start with a high thermal load on the user side is envisaged, it may be useful to equip the unit with the "Cold start" accessory to keep the compressor functioning within its permitted operating range.

The proposed scheme must be respected to allow the maintenance of the flow rate to the user side exchanger (condenser), it also allows the control the inlet temperature to the condenser by injecting hot water.

The analogue control signal comes from an additional card included in the accessory and assembled in the unit's electrical panel.

If the 3-way valve is not supplied, bear in mind that the control signal is only and exclusively 0-10V (IVC option).

The servomotor of the same must necessarily be able to be controlled by this signal.

! The valve is supplied, but the installation must be carried out on site following the principle diagram shown.

! The valve must be installed near the unit.

5. Electrical connections

- 5.1 Machine connection
- 5.2 Connections of the accessories

5.1 Machine connection

A Pre-cut-out for side entry

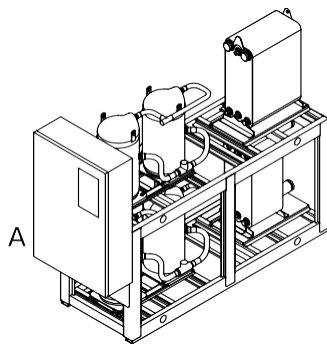
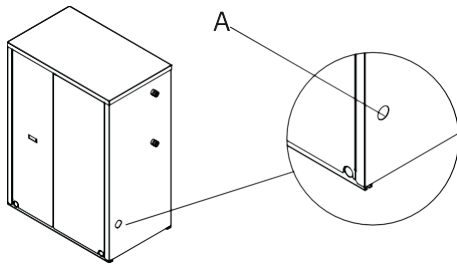

The unit is provided with holes for the power cables inlet. There is a pre-cut hole on the structure and a hole on the base for any input from below.

- Remove the pre-cut.
- Insert the cables from the outside, guiding them towards the electrical board.

⚠ Avoid direct contact with non-insulated copper pipes and with the compressor.

⚠ Do not enter the device with electrical cables in positions not specifically required in this document.

- A Cable gland for power cable input
- B Power terminal blocks
- C Cable gland for control cables input
- D Control terminal block

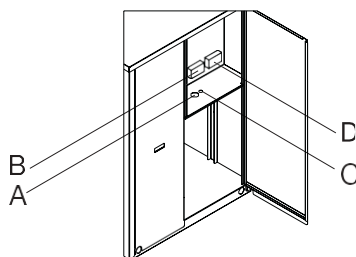

To set up the electrical connections:

- Unscrew the fixing screws.
- Remove the external panels.

- Set the main switch to 0.
- Turn the two fixing screws 1/4 of a turn and open the board doors.
- Use the hole for the main power cable and the hole for the cables of other external connections.
- Make the connections as shown in the wiring diagram.
- Once the electrical connections are completed, secure the cables by using the cable glands, close the doors of the electrical panel and reassemble the external panels by screwing the fixing screws.

⚠ Before connecting the remote ON-OFF switch, remove the jumper from the relative clamps.

5.2 Connections of the accessories

5.2.1 Flow switch

The unit must work in the presence of water flow only. The flow switch (if not already present) must be connected as shown in the wiring diagram.

5.2.2 Circulating pump

The circulating pump must always be connected to the control unit as indicated in the wiring diagram. The pump must be started before the unit starts and stopped after it has stopped (minimum recommended delay: 60 seconds).

5.2.3 External consents

If you wish to enable or disable the unit remotely, connect the external consent to the contacts listed in the wiring diagram.

⚠ Avoid placing the control cables in the same duct as the power cables. Always use a suitable shielded cable.

⚠ The connection cables must have a minimum cross section of 1.5 mm².

5.2.4 Connections of the accessories

5.2.4.1 Circulating pump

The circulating pump must always be connected to the control unit as indicated in the wiring diagram. The pump must be started before the unit starts and stopped after it has stopped (minimum recommended delay: 60 seconds).

6. Commissioning

- 6.1 Preliminary inspections
- 6.2 First start-up or restart after long inactivity
- 6.3 Shut-down
- 6.4 Flow rate calibration

6.1 Preliminary inspections

6.1.1 Electrical

- Verify that the voltage on terminals L1, L2 and L3 is that shown on the plate of the unit (tolerance allowed) $\pm 5\%$, which can be checked with a tester. If voltage changes occur frequently, please contact our technical department to choose suitable protections.
- Verify the complete tightness of the fuse holder caps.
- Verify that the crankcase heaters (if applicable) are powered correctly: to check whether the heaters are working properly, check that the bottom of the compressor is at a temperature of 10 to 15 °C higher than the ambient temperature.
- Power and check the correct direction of rotation for the three-phase version, which should be clockwise looking at the motor from the fan side. Otherwise, invert any two of the phase conductors.

6.1.2 Hydraulic

- Make sure that the water circuit has been previously cleaned: it is recommended to wash the water circuit via by-passing the unit and then check the cleanliness of the system filter.
- The machines are shipped with open vents and drains, which must be closed during installation when filling the water circuit. Labels indicate their positions.
- In models with a hydronic kit, the water drain cap of the pump has been removed, in order to drain the water contained in it and to avoid freezing problems during the winter season. The cap is inside the envelope containing all documents of the unit.
- Make sure that the hydraulic system has been bled, thereby eliminating any residual air. The operation must be performed by loading gradually and opening the venting devices set up by the installer in the upper part of the system.
- If you are using glycol water you can move the antifreeze set-point. The value must be equal to the value of the freezing temperature of the fluid plus 6K.

6.1.3 Cooling

- Make sure that the pressure gauges (when present) indicate an adequate pressure. Pressure gauges can be fitted with shut-off valves. They should only be opened when necessary and once readings are taken, they must be closed again.
- Check that there is no refrigerant leak, possibly using a leak detector.

6.2 First start-up or restart after long inactivity

6.2.1 Start-up

Activate the machine according to that described in the relative command section.

6.2.1.1 Checks during operation

- Check that the machine does not generate abnormal noise or excessive vibrations.
- After a few hours of operation verify that the crown of the liquid and humidity indicator indicates a dry circuit.
- Verify that the machine operates within the optimum working range.
- Verify that there is no excessive presence of bubbles in the liquid indicator. If there are this indicates low refrigerant.
- A few minutes after starting the compressors, during the summer operating cycle, make sure that the condensation temperature is $> 5 \pm 2K$ with respect to the condenser outlet water temperature and that the evaporation temperature is $5 \pm 2K$ lower than the evaporator outlet water temperature.
- Verify that the overheating temperature of the refrigerant is between 5 and 7K. To verify:
 - Measure the temperature with a contact thermometer placed on the intake pipe of the condenser.

- Read the temperature indicated on the pressure gauge connected to the inlet.
- The difference between these temperatures provides the overheating value.
- Verify that the subcooling temperature of the refrigerant is between 4 and 8K. To verify:
 - Measure the temperature with a contact thermometer placed on the outlet pipe from the condenser.
 - Read the temperature indicated on a pressure gauge connected to the liquid outlet of the condenser.
 - The difference between these temperatures provides the subcooling value.

⚠ The tests referred to above can be performed using the pressure gauges supplied with the unit (accessories). Once the checks are complete, close the shut-off valves of the pressure gauges.

6.2.2 Pump release procedure

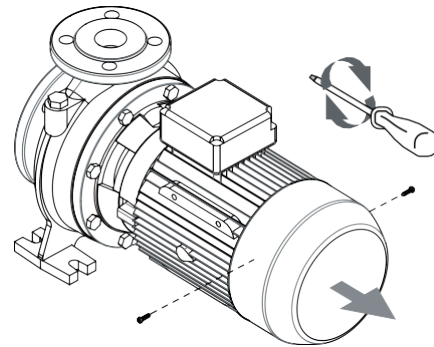

- Before starting the pump, check that the moving parts rotate freely.
- To release the pump:
- Remove the fan cover from the seat of the rear motor cover.
 - Use a screwdriver on the present slot on the motor shaft from the fan side.
 - In case of blockage, turn the screwdriver by tapping it lightly with a hammer.
 - When the operations are completed, reassemble the components in reverse order.

6.3 Shut-down

6.3.1 Temporary shut-down

Disable the machine according to that described in the relative command section.

⚠ Do not disconnect the power supply by acting on the disconnecting switch on board the machine or the main switch of the system. If no voltage is present, the crankcase heaters and any anti-freeze heaters cannot work, thereby, posing a risk of freezing.

6.3.2 Shut-down for long periods

Not using the unit for a long period of time requires the following operations to be performed:

- Disable the unit in any mode of operation it may be, from the control panel.
- Set the remote switch to "OFF" (if present) after having turned off the unit.
- Disable the internal terminal units by setting the switch of each unit to "off".
- Set the main switch of the system to "off".
- Close the water valves.

 If, during the period of inactivity the temperature drops below zero, the system must be fully emptied or topped up with antifreeze liquid.

6.4 Flow rate calibration

Once the pump has started, verify that the fluid flow rate of the utilities is within the expected values for the unit.

To verify:

- Use pressure gauges set before and after the circulating pump to measure the pressure difference.
- Verify that the pressure difference measured is equal to the pressure drop in the system, including the heat exchanger.

To correct:

- Turn the valve installed downstream of the pump to increase or decrease the pressure difference.
- Mark the position of each valve to reposition it in the same position after closing for maintenance operations.

If there are no pressure gauges:

- Verify the temperature difference between the utility fluid input and output when the unit is operating regularly (all compressors on).
- The difference in water temperature between input and output must be between 4° and 6°C:
 - If it is below 4°C, the water flow rate is too high: slightly close the discharge valve of the pump.
 - If it is more than 6°C, verify the pressure drops in the water circuit.

 For units equipped with two pumps, you will have to repeat the calibration for each pump.

7. Control Panel

- 7.1 User interface
- 7.2 Switch on and off
- 7.3 Settings
- 7.4 Unit Status
- 7.5 Alarms
- 7.6 Login
- 7.7 Software
- 7.8 Electric control information

7.1 User interface

7.1.1 Control panel

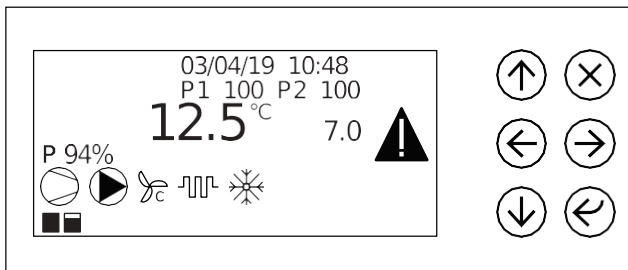

The control panel enables all machine functions to be performed, to display its operation and any alarms which may be triggered.

7.1.2 Display

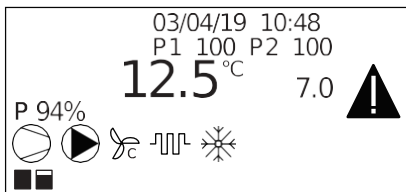

From the display of the control panel it is possible to see the sizes of the values set and machine operation may be displayed through the LEDs.

Date and time

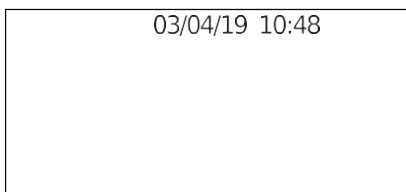

Indicates the date and time set.

Set water temperature

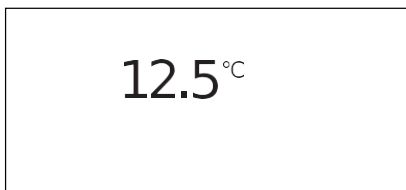

It indicates the outlet water temperature

Set-point



Indicates the Set-Point temperature.

Alarm



Indicates that a machine operation alarm has triggered.

Compressor



Indicates compressors operation:

Compressor capacity steps

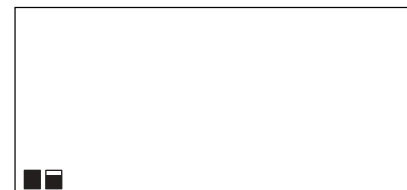

Indicates the way in which the compressors are distributing.

Requested power



It indicates the power percentage requested by the machine

Pumps

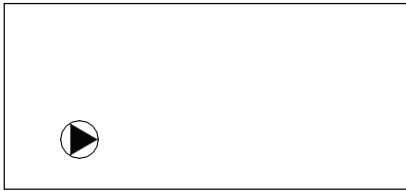

Indicate pumps operation.

Unit power

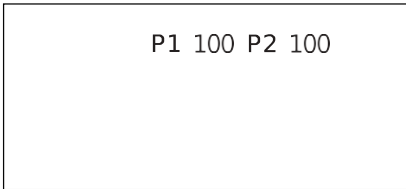

It indicates the actual power quantity of the unit: P1 power circuit 1; P2 power circuit 2.

Cooling

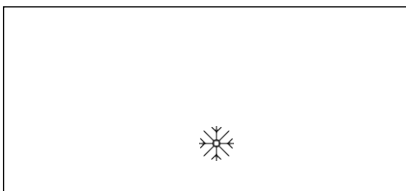

Indicates that the machine is operating in cooling mode.

Heating

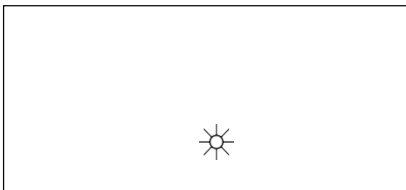

Indicates that the machine is operating in heating mode.

Defrosting

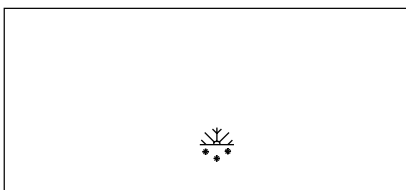

Indicates that the machine is operating in defrosting mode.

Resistance

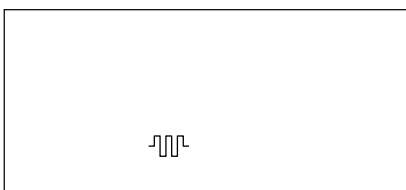

Indicates heater operation.

Scrolling message

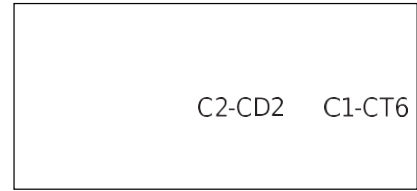

The flowing message can indicate some unit operations or alarms.

7.1.3 Function keys

UP Function

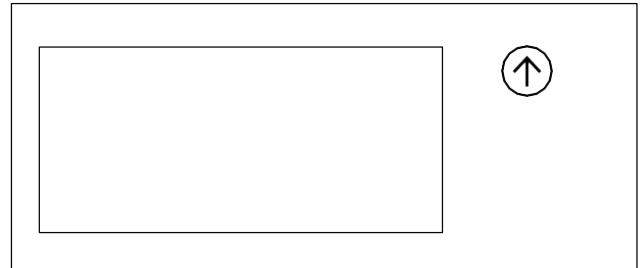

By using the UP key it is possible to move upwards between the parameters and increase a value. The extended pressure of UP button allows to turn on or off the unit.

DOWN Function

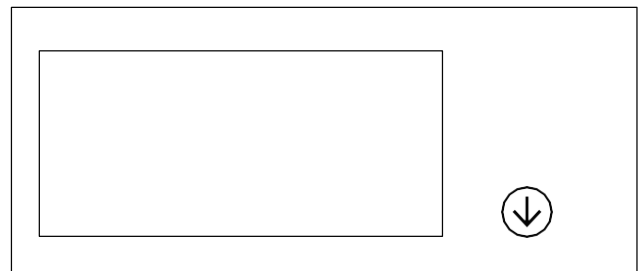

By using the DOWN key it is possible to move downwards between the parameters and decrease a value.

ENTER Function

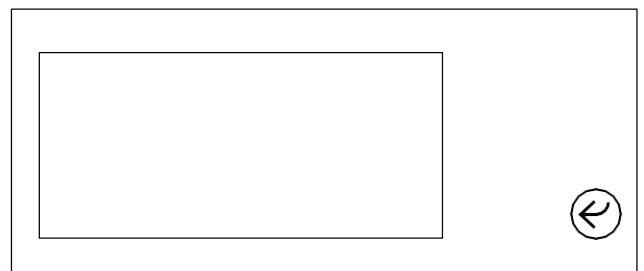

Enter a menu and save a value by using the ENTER key.

RIGHT Function

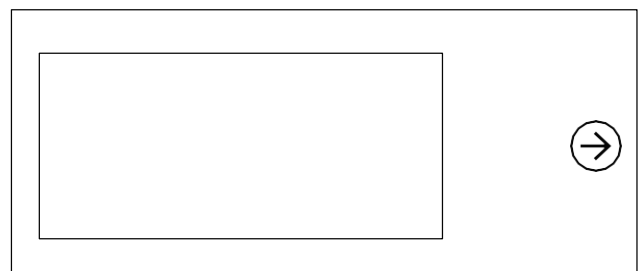

By using the RIGHT key it is possible to move to the right within the parameters.

LEFT Function

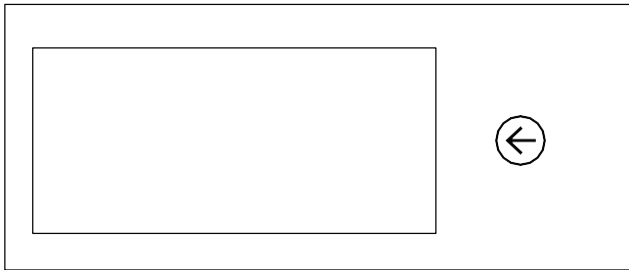

By using the LEFT key it is possible to move to the left within the parameters.

ESC Function

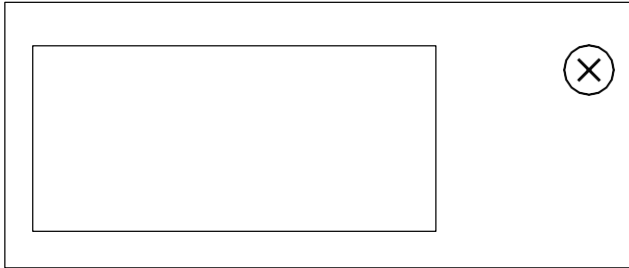

By using the ESC key it is possible to exit a menu and display an alarm that has triggered. The extended pressure of ESC button allows to reset active alarms.

7.2 Switch on and off

Press the ENTER key to access the main menu in order to switch the unit on or off.

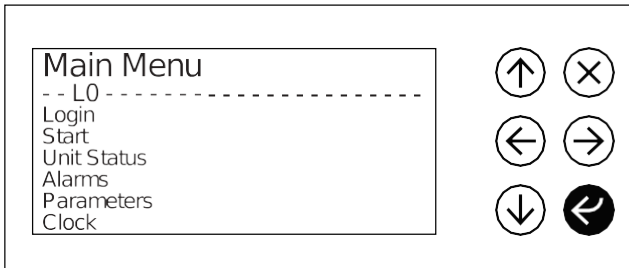

Select the start-up menu.

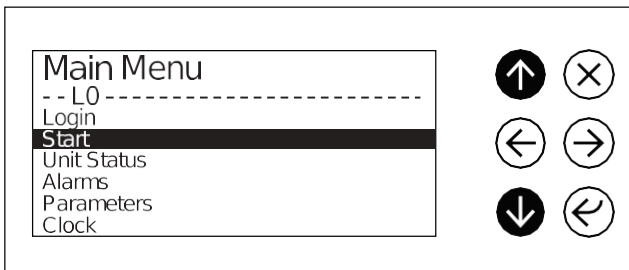

Press the ENTER key.

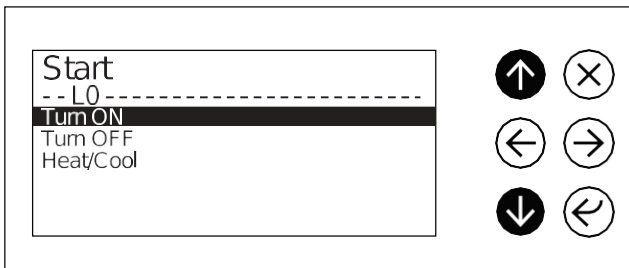

By using the UP and DOWN keys it is possible to select unit start-up, shutdown or to change its operating mode.

Press the ENTER key to confirm.

The unit can be switched on or off directly from the main screen: pushing the UP key for 5 seconds the unit switches from on to off and vice versa.

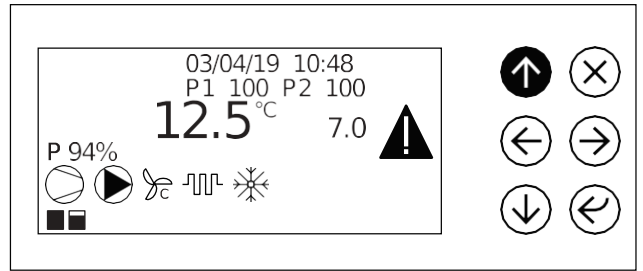

If the machine is switched off, the display will show the sign OFF.

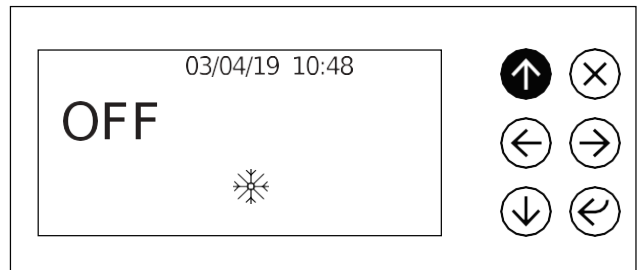

7.3 Settings

7.3.1 Language

It is possible to select the software language. Press the ENTER key to access the main menu.

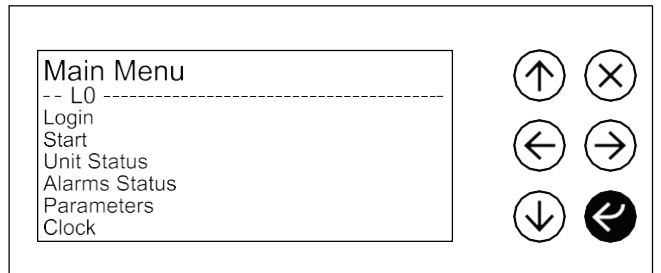

Select the language menu. Press the ENTER key.

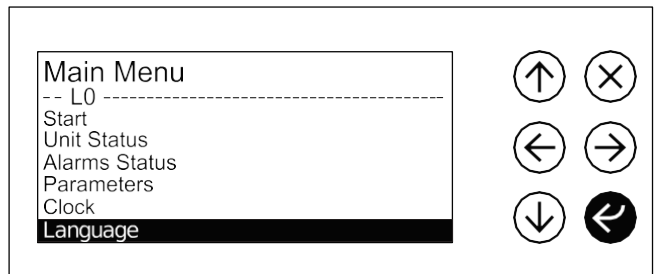

Select the desired language from those available. Press the ENTER key to confirm.

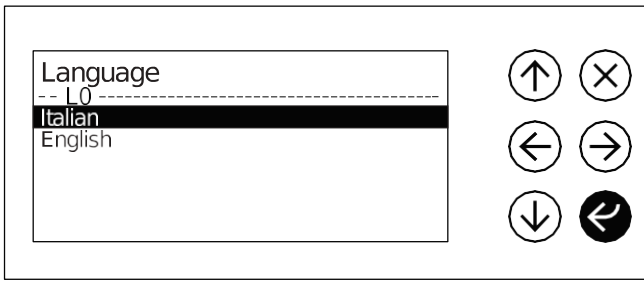

All software contents will appear translated in the language selected.

7.3.2 Date and time

The adjustment must be made while the machine is off.
Press the ENTER key to access the main menu.

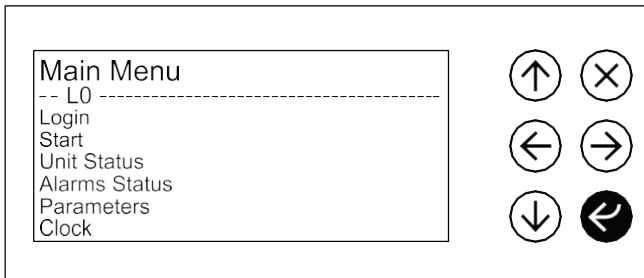

Select the clock menu.
Press the ENTER key.

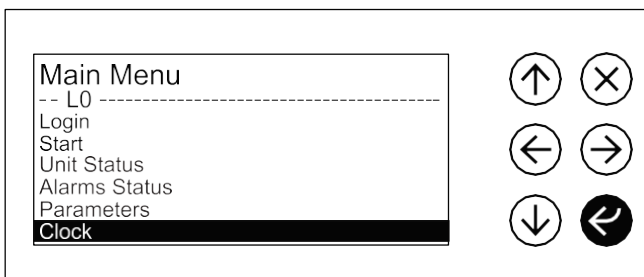

Select Set RTC menu and push the ENTER button.

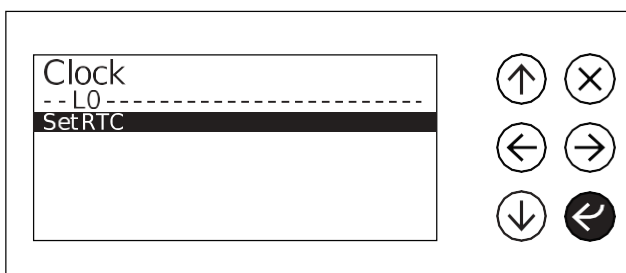

Using the control panel arrows, move the cursor on the value to modify.
Press the ENTER key.

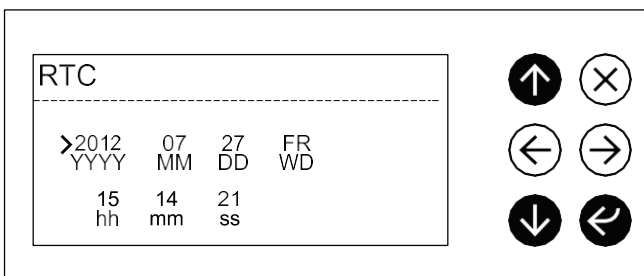

Modify the value by using UP and DOWN buttons.

Press the ENTER key.
Press the ESC key to exit.

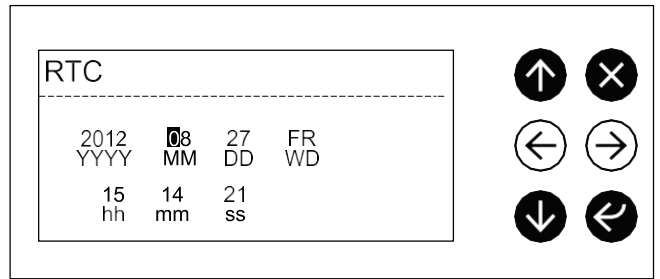

7.3.3 Set-point

From control panel it is possible to set the water temperature value (outlet water).
Press the ENTER key to access the main menu.

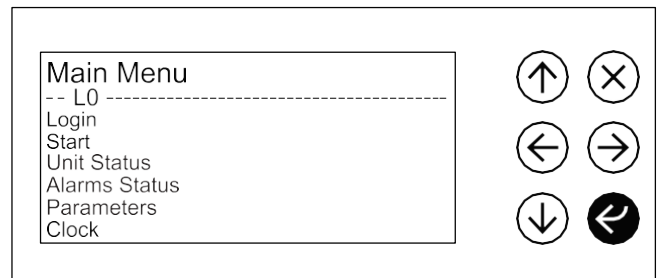

Select the parameter menu.
Press the ENTER key.

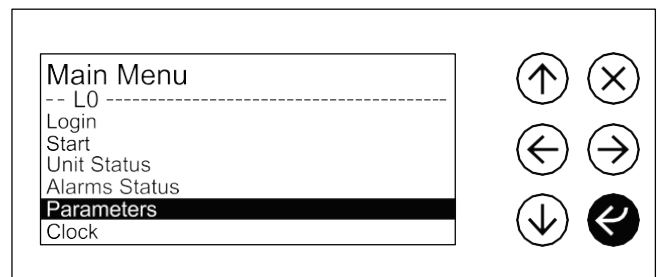

Select the adjustment menu.
Press the ENTER key.

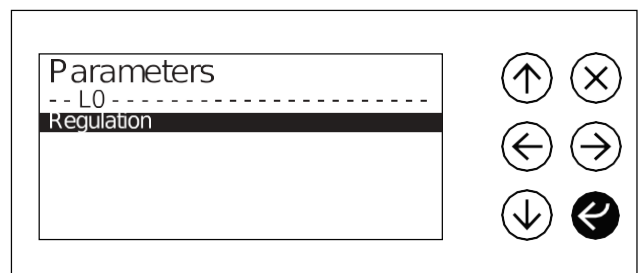

Select the Setpoint menu.
Press the ENTER key.

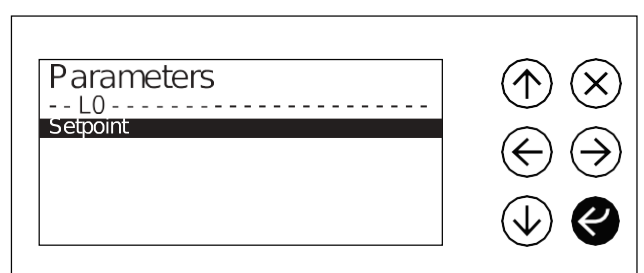

By using the UP and DOWN keys it is possible to select the set-point to modify: SC1 summer set-point.

Press the ENTER key to modify the value.

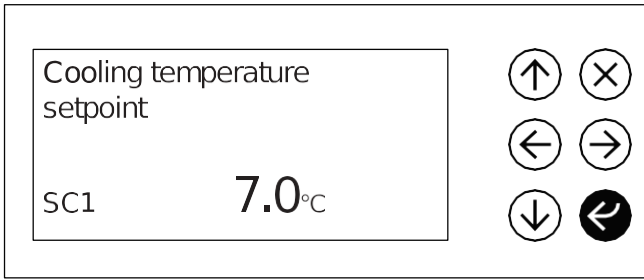

Use the UP and DOWN keys to modify the value.

Press the ENTER key to confirm.

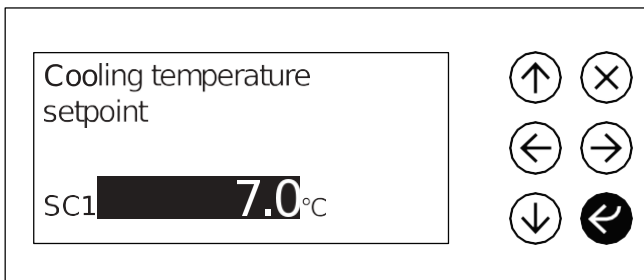

Second set-point (accessory).

 The setting of second set-point value is password-protected.

The second set-point is a value expressed in Kelvin which indicates the temperature difference of the set-point obtained by its enabling.

The value can be set and then, only for units equipped with the IAS accessory (factory fitted accessory), enabled or disabled.

From the adjustment menu, select the second set-point menu and press the ENTER key.

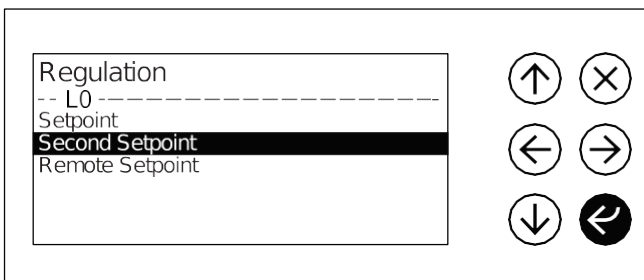

By using the UP and DOWN keys it is possible to choose between the second machine set-point in the heating or cooling operating mode.

Once the second set-point you wish to change has been selected, press the ENTER key and set the desired value by using the UP and DOWN keys.

Press the ENTER key to confirm.

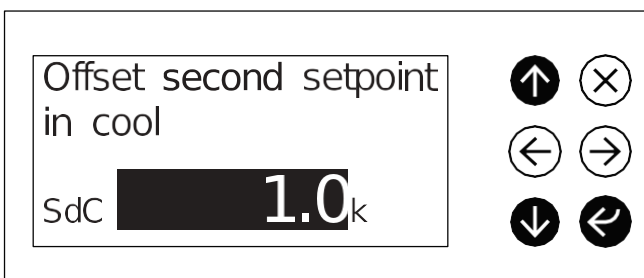

Remote set-point (accessory)

In units fitted with the IAV or IAA accessory (factory fitted accessories), the set-point can be modified by using a remote signal.

Operation can be enabled by using the remote set-point function.

From the adjustment menu, select the remote set-point menu and press the ENTER key.

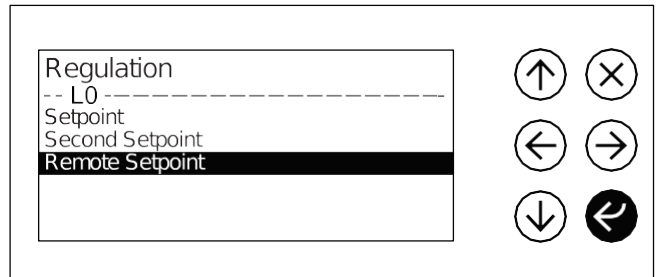

Press the ENTER key.

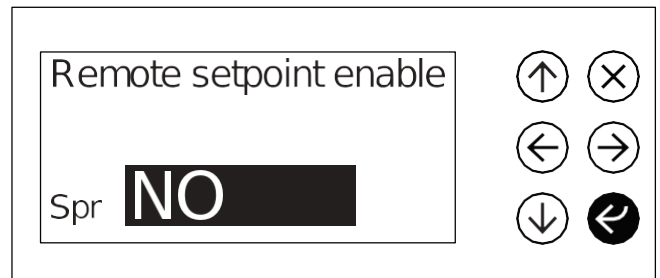

The remote set-point can be enabled or disabled by using the UP and DOWN keys.

Press the ENTER key to confirm.



7.4 Unit Status

The unit status can be displayed.

Press the ENTER key to access the main menu.

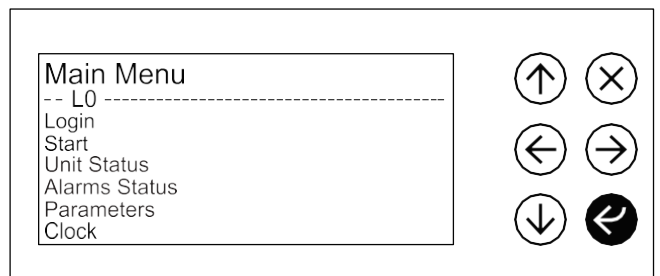

Select the Unit Status menu.

Press the ENTER key to access the Unit Status menu.

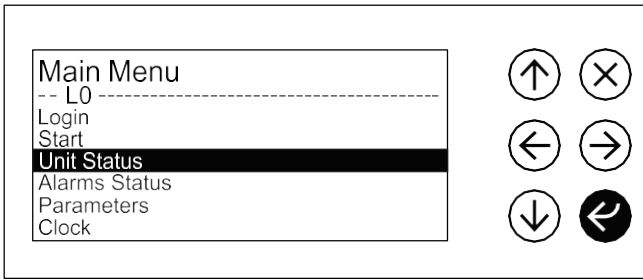

Inputs and outputs

Select the Input/Output menu.

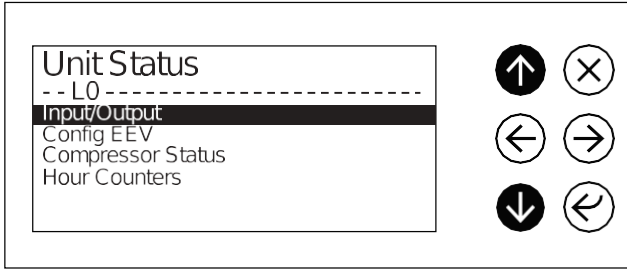

Press the ENTER key to access the Input/Output menu.

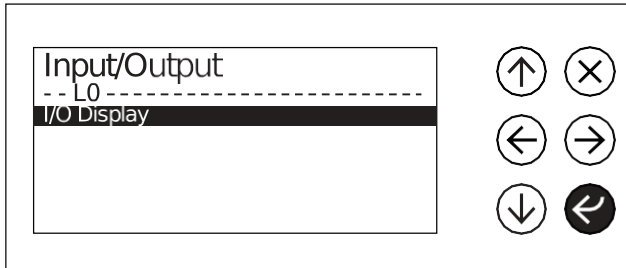

Press the ENTER key to display the status.

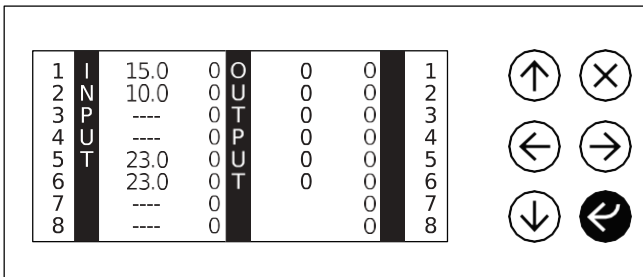

By using the UP and DOWN keys it is possible to scroll through the inputs and outputs status list.

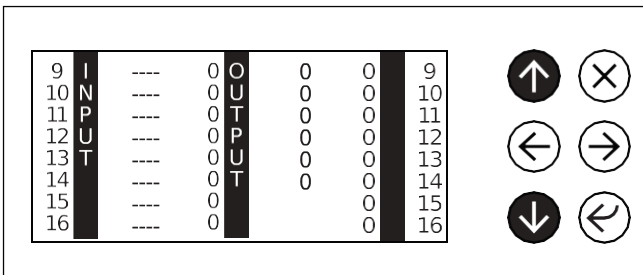

Expansion valve

Select the Expansion valve menu.

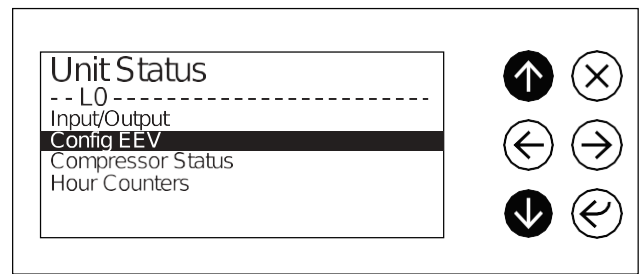

Select one of the solenoid valves.

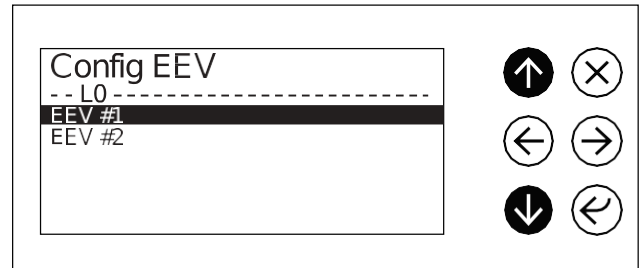

Press the ENTER key.

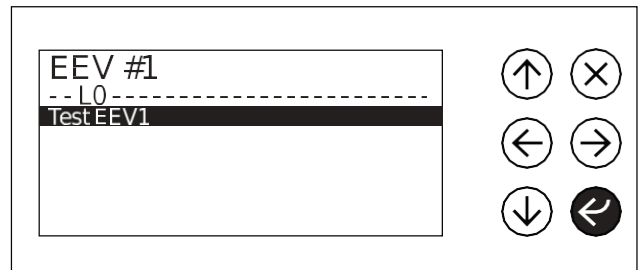

Press the ENTER key to display the expansion valve status.

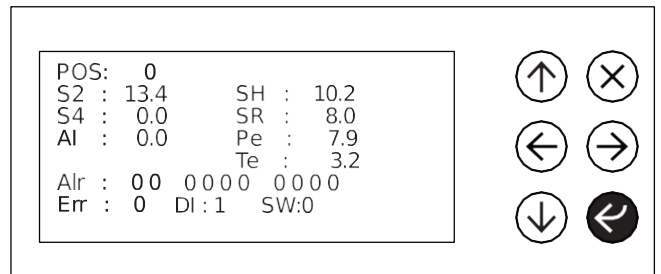

The operation can be repeated for both expansion valves.

Compressor status

Select the compressor Status menu.

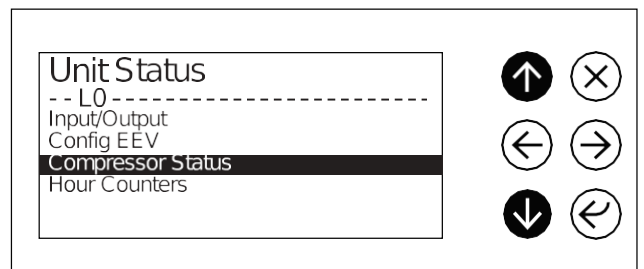

Press the ENTER key to display the compressors status.

Counter

Select the Counter menu.

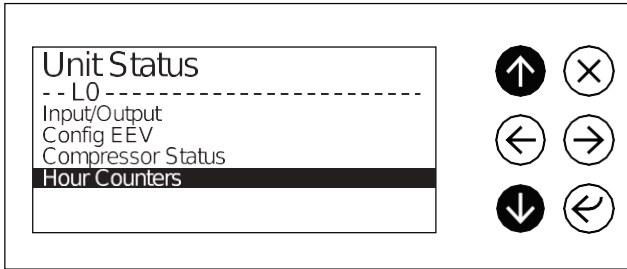

Press the ENTER key to display the counters status.

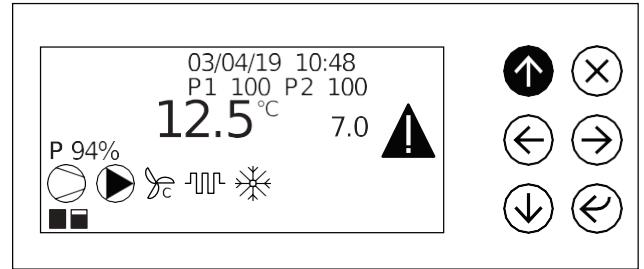

Press the ENTER key to access the main menu.



Press the ENTER key to display the compressor counter.

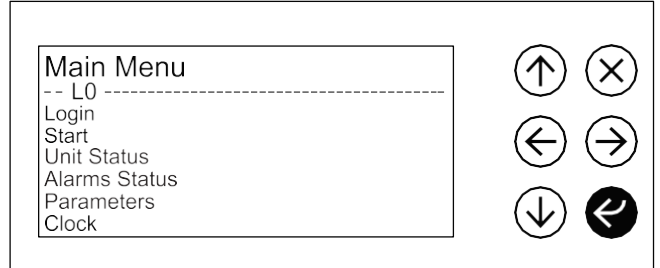

Select the ALARMS Status menu.

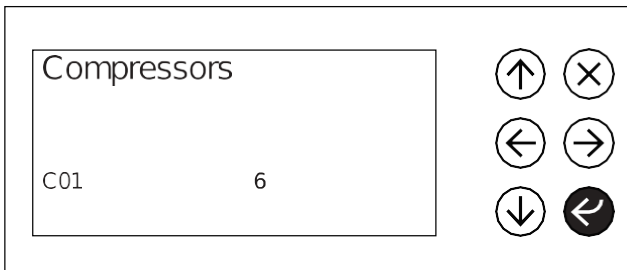

Use the UP and DOWN keys to display the status of all compressors.

Press the ESC key to return to the main menu.

Select the evaporator pump menu.

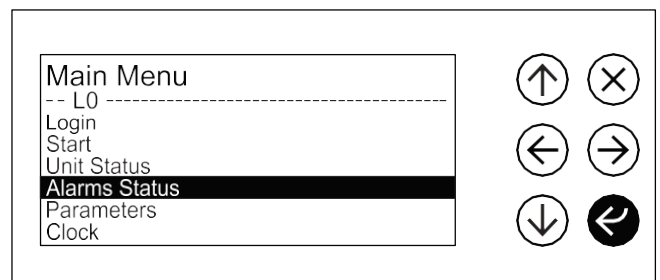

Press the ENTER key to access the ALARMS menu.

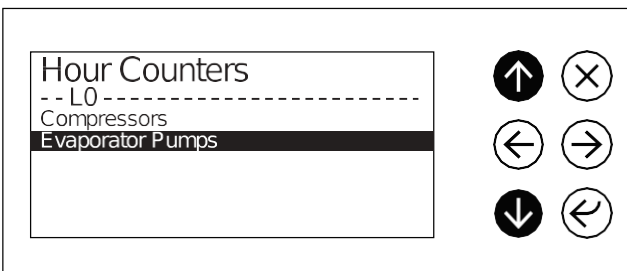

Press the ENTER key to display the evaporator pump counter.

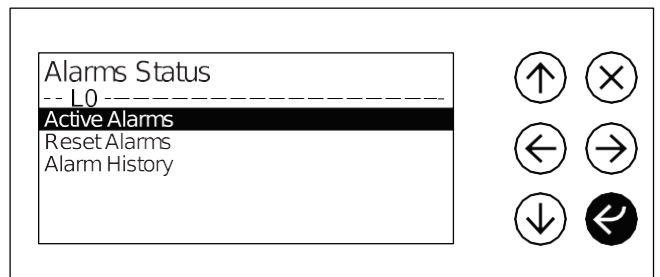

Press the ENTER key to display the active alarms.

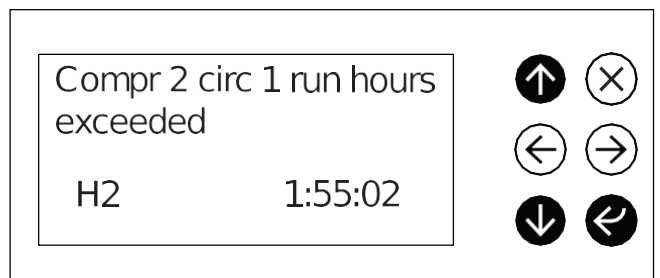
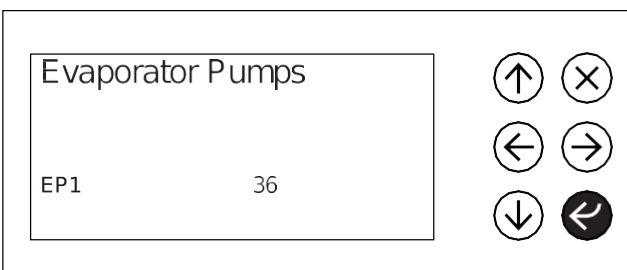

If multiple alarms have triggered, you can scroll through the list by using the UP and DOWN keys.

It is also possible to access the list of alarms triggered from the main screen by pressing the ESC key.

7.5 Alarms

7.5.1 Alarm presence

In case of machine malfunction, the ALARM symbol appears on the display.

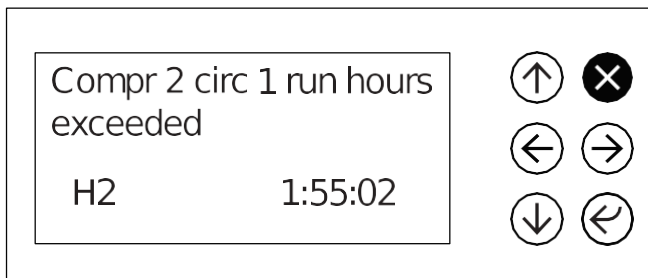

It is also possible to reset an alarm directly from the main screen. From the main screen, press the ESC key to display the alarm triggered.

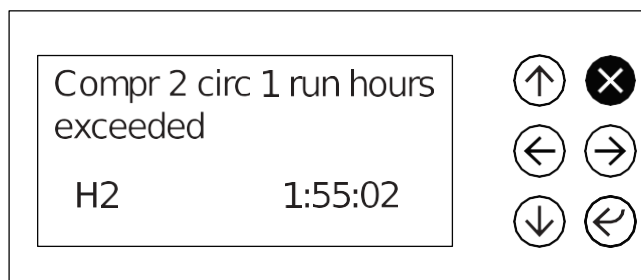

7.5.2 Alarms reset

Some alarms can be reset directly from the control panel.

Press the ENTER key to access the main menu.

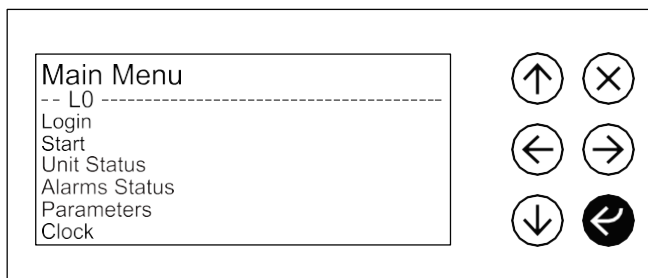

Press and hold the ESC key for 5 seconds.

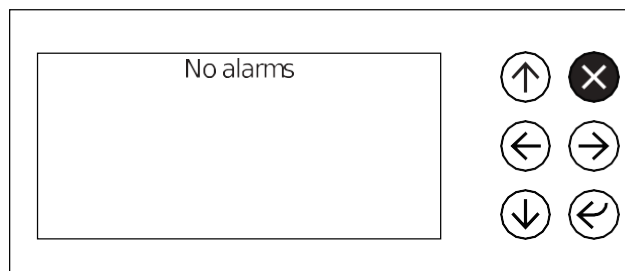

Select the ALARMS Status menu.

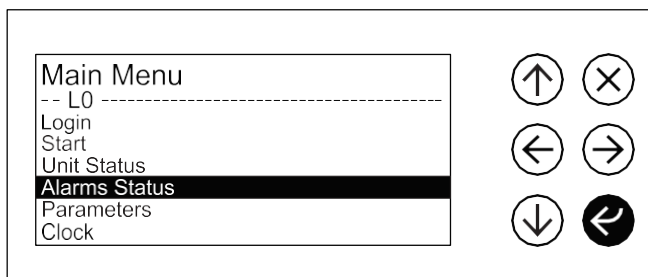

Press the ESC key to return to the main screen.

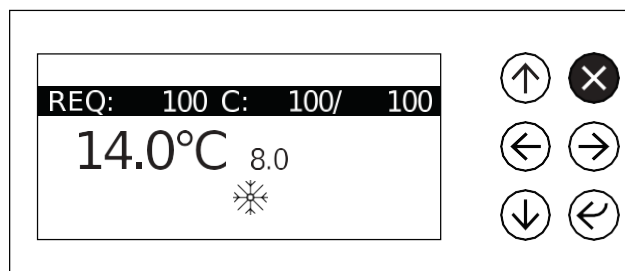

Press the ENTER key to access the ALARMS menu and select the Alarms Reset menu.

7.5.3 Alarms history

It is possible to display the alarms history triggered on the machine.

Press the ENTER key to access the main menu.

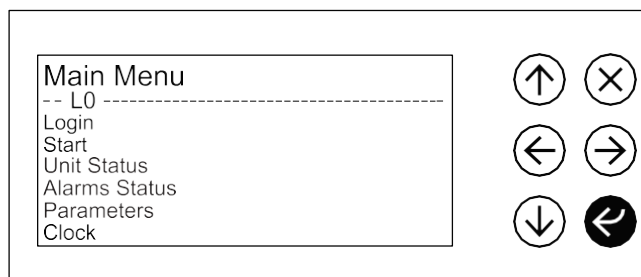
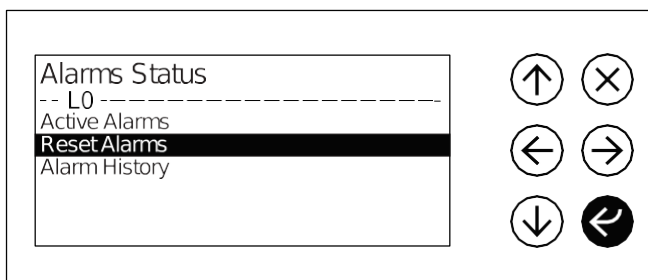

Pressing the ENTER key resets the alarms and the control panel goes back to the main screen. If the alarms are reset correctly, the alarm icon is no longer present.

Select the ALARMS Status menu.

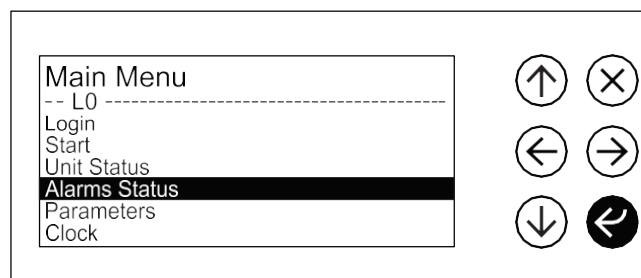
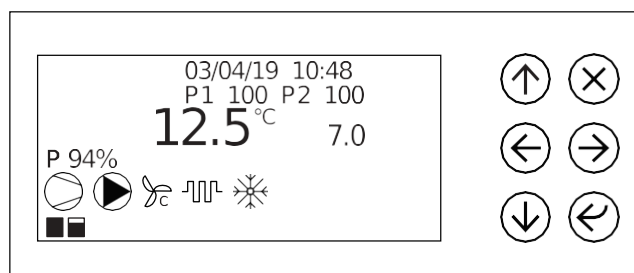

Press the ENTER key to access the ALARM menu and select the Alarms History menu.

⚠ Some alarms require a reset directly on the device, therefore reset the device before performing the reset on the control panel.

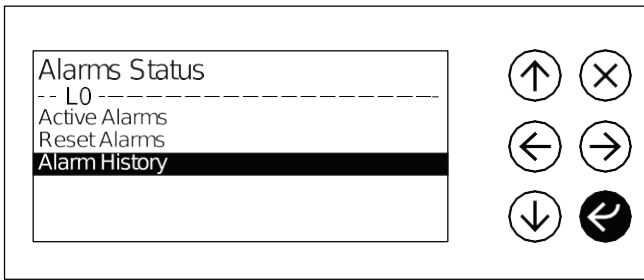

Press the ENTER key to display the alarms triggered history.

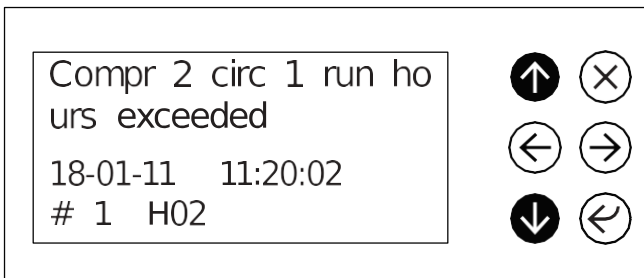

By using the UP and DOWN keys it is possible to display the list of alarms triggered with relative date and time of the event.

7.6 Login

To access the advanced functions of the control panel it is required to access the password protected menus.

Press the ENTER key to access the main menu.

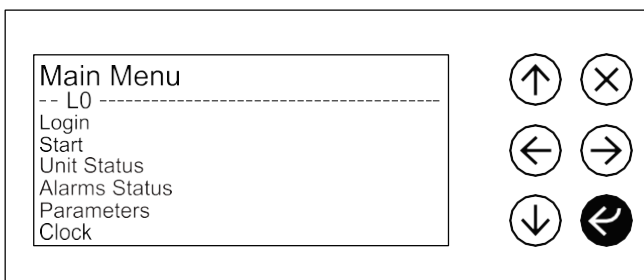

Select the login menu.
Press the ENTER key.

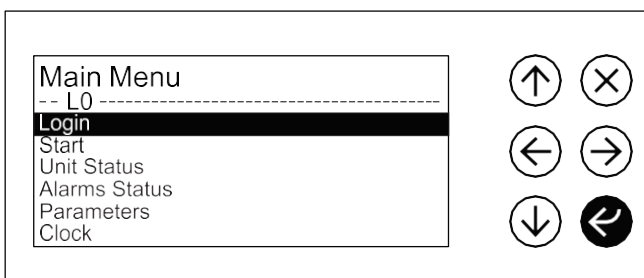

By using the UP and DOWN keys it is possible to edit the highlighted password value.
Press the ENTER key to confirm.



Edit all fields by entering the password.



The advanced functions menus can be accessed by entering the password.

7.7 Software

It is possible to obtain information on the software installed on your machine.
Press the ENTER key to access the main menu.

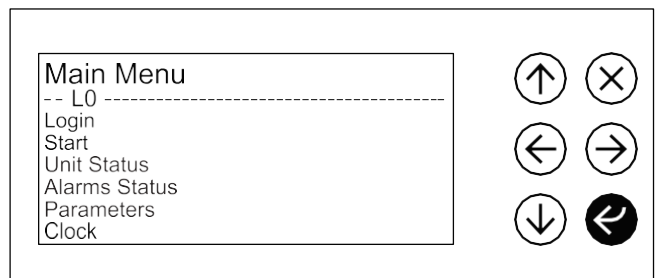

Use the UP and DOWN keys to select the DEVICE INFO menu.

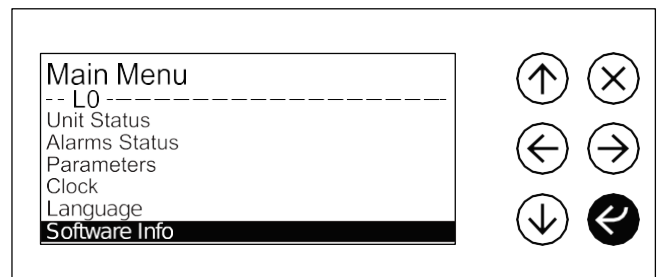

Press the ENTER key.
This screen displays the version of the software installed.

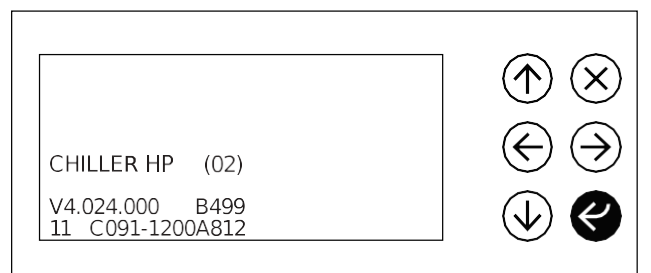

7.8 Electric control information

It is possible to get information about electric control on which the software is installed.
Press the ENTER key to access the main menu.

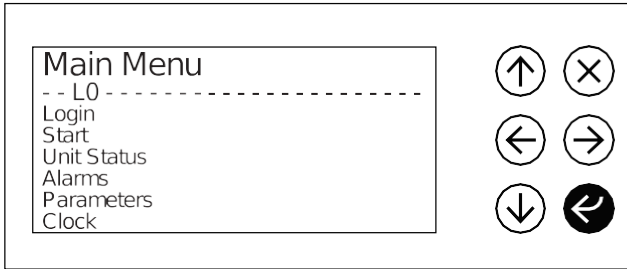

Use the UP and DOWN keys to select the DEVICE INFO menu.

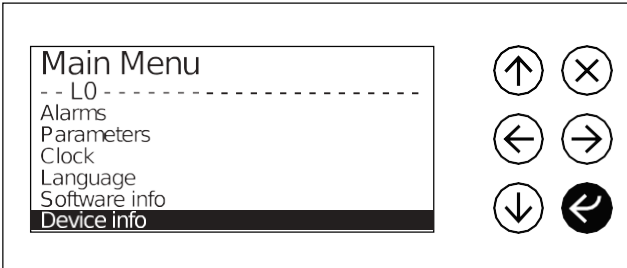

Press the ENTER key.

From this screen you can view the information of the machine on which the software is installed.

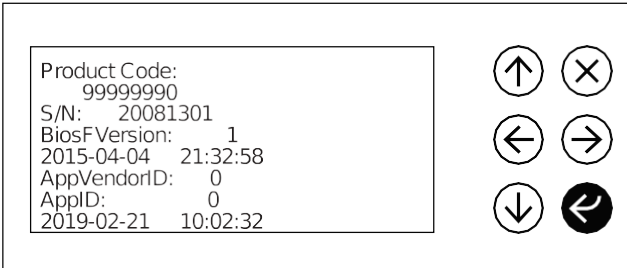

8. Maintenance

- 8.1 Maintenance
- 8.2 Weekly checks
- 8.3 Monthly checks
- 8.4 Annual checks
- 8.5 Water circuit
- 8.6 Refrigerant circuit
- 8.7 Decommissioning and disposing

8.1 Maintenance

Regular maintenance is essential to maintain the efficiency of the unit in terms of operation and energy.

The maintenance schedule that the Service or the Refrigerator Technician must observe with regular frequency, involves the following operations and checks.

8.2 Weekly checks

Regular maintenance is essential to maintain the efficiency of the unit in terms of operation and energy.

The maintenance schedule that the Service or the Refrigerator Technician must observe with regular frequency, involves the following operations and checks.

8.2.1 Routine maintenance

The routine maintenance operations are the cleaning and control of machine components or parts that may compromise its operation, safety or efficiency.

These operations must be performed by qualified personnel and enabled to work on this type of products.

All maintenance operations must be performed with the machine off and electrically isolated, paying particular attention to the safety instructions and laws in force in the country of operation. The machine can be restarted after completing the routine maintenance operations, checking its proper operation.

8.2.2 Extraordinary maintenance

The extraordinary maintenance operations are the replacement and the repair of machine components or parts that compromise its operation, safety or efficiency.

These operations must be performed by qualified personnel and enabled to work on this type of products.

All maintenance operations must be performed with the machine off and electrically isolated, paying particular attention to the safety instructions and laws in force in the country of operation. After completing the repair and replacement operations, the machine can be restarted following the first start-up instructions, verifying its proper operation.

8.3 Monthly checks

- Verify the tightness of the terminals inside the electrical board and in the terminal board of the compressors. Check the mobile and fixed contacts of the remote switches and replace them if deteriorated.
- Verify the complete tightness of the fuse holder caps.
- Verify the proper refrigerant charge in the circuit through the liquid and humidity indicator.
- Check that the compressor is not leaking oil.
- Verify that the fan of the electrical board (if applicable) works properly.
- Verify that there are no abnormal vibrations of the compressor.
- Verify that the power consumption of the compressor falls within the plate limits.
- Verify that the temperatures and pressures of the compressor fall within those indicated for proper operation.
- Check that the water circuit does not leak water.
- Vent the hydraulic system.
- Check any compressors crankcase heaters.
- Clean the metal filters in the hydraulic pipes.
- Verify that the noise emission of the machine is regular.
- Check that any antifreeze heaters are working properly.

- Verify that the following safety devices work properly:
 - High pressure switch;
 - Low pressure switch;
 - Compressor protection module;
 - Water flow switch;
 - Defrost sensor;
 - Check the correct reading of the temperature and pressure sensor.
- Check the following operating factors:
 - Subcooling and superheating of the refrigerant;
 - No bubbles on the liquid indicator;
 - Refrigerant leaks near the joints;
 - Proper closure of the solenoid valve (if applicable);
 - The temperature difference of the liquid used for utilities between inlet and outlet.

8.4 Annual checks

- Proceed with the verification of the fastening, balancing and general conditions of the fans.
- Verify the colour of the liquid and humidity indicator; if the colour indicates a wet circuit, the filter must be replaced.
- Check the condition of the paint: any scratches should be touched up to prevent corrosion.
- Verify the cleanliness of the heat exchanger on the air side.
- Verify the cleanliness of the metal guard filter on water circuit.

8.5 Water circuit

8.5.1 Water circuit load

- Before starting to load, set the main switch of the system to "off".
- Open the rear inspection panel of the unit.
- Check that the unit and system drain valves are closed.
- Open all vent valves of the unit, of the system and of the related terminals.

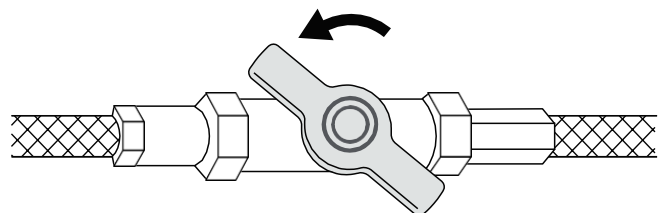

- Open the shut-off devices of the system.
- Start filling by slowly opening the system water fill-up valve outside the unit.
- When water begins to leak from the air vents, close them and continue filling until the expected system pressure value is reached.

⚠ Verify the hydraulic tightness of the joints.

⚠ It is advisable to repeat this operation after the unit has been operating for a few hours and regularly check the system pressure. Top-ups must be carried out with the machine off (pump OFF).

⚠ The system must be filled to a pressure range between 1 and 2 bar.

8.5.2 Draining of the water circuit

- Before starting to load, set the main switch of the system to "off".
- Open the rear inspection panel of the unit.
- Check that the unit and system drain valves are closed.
- Open all vent valves of the unit, of the system and of the related terminals.

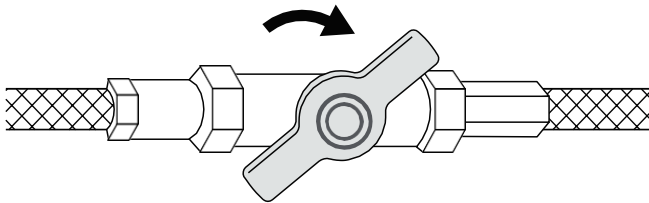

- Before starting to load, set the main switch of the system to "off".
- Before starting to empty, set the main switch of the system to "off".
- Open the rear inspection panel of the unit.
- Verify that the system water load/top-up valve is closed.

⚠ If the system is supplemented with antifreeze liquids, this should not be drained freely because of pollution. It must be collected and possibly reused.

8.5.3 Exchanger cleaning

The material not trapped by the filters, the water hardness or the high concentration of low freezing point solutions may dirty the water exchangers, reducing the efficiency of the heat exchange.

By using a differential pressure gauge it is possible to check the pressure loss between exchanger inlet and outlet.

If, from an inspection, it is found that the pressure values compromise regular operation or reduce machine efficiency, cleaning the exchanger will be required.

The exchangers must be cleaned with the machine off and by personnel authorised and trained for this type of operation.

The exchangers must be cleaned by using the specific pressure sockets and with specific detergents. At the end of the cleaning operation the exchangers must be appropriately rinsed to prevent detergent from circulating in the system.

At the end of the operation the water system must be reloaded and vented before restarting.

8.6 Refrigerant circuit

8.6.1 Cooling circuit repair

⚠ These operations should be carried out only by qualified personnel, using standard techniques typical of cooling systems that use halogen fluids such as refrigerants.

8.6.2 Refrigerant top up

They should be carried out only after having identified and repaired the leaking points.

⊖ No more than two top-ups are permitted. If an additional top-up is required, the cooling circuit must be emptied completely and filled with virgin refrigerant.

8.7 Decommissioning and disposing

This product falls within the field of application of Directive 2012/19/EU on the management of waste electric and electronic equipment (WEEE).

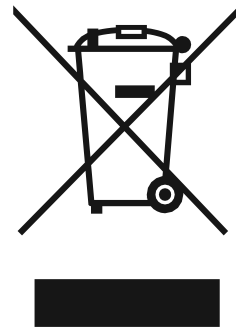

⚠ These types of products may contain substances that are potentially harmful to human health and the environment and cannot be disposed of as household waste.

When the machine needs to be replaced or dismantled it must be disposed of according to local regulations on sorted waste, otherwise you must contact your local dealer for information on free pick-up.



Trane - by Trane Technologies (NYSE: TT), a global climate innovator - creates comfortable, energy efficient indoor environments for commercial and residential applications. For more information, please visit trane.eu or tranetechnologies.com.
Trane has a policy of continuous product and product data improvement and reserves the right to change design and specifications without notice.

CG-SVX056A-GB_1121
New

©2021 Trane